

LS 55

User's Guide

Release History

Part Number	Release	Publication Date
09934436	C	March 2007

Any comments about the documentation for this product should be addressed to:

User Assistance
PerkinElmer Ltd.
Chalfont Road
Seer Green
Beaconsfield
Bucks
HP9 2FX
United Kingdom

Or emailed to: info@perkinelmer.com

Notices

The information contained in this document is subject to change without notice.

Except as specifically set forth in its terms and conditions of sale, PerkinElmer makes no warranty of any kind with regard to this document, including, but not limited to, the implied warranties of merchantability and fitness for a particular purpose.

PerkinElmer shall not be liable for errors contained herein for incidental consequential damages in connection with furnishing, performance or use of this material.

Copyright Information

This document contains proprietary information that is protected by copyright. All rights are reserved. No part of this publication may be reproduced in any form whatsoever or translated into any language without the prior, written permission of PerkinElmer, Inc.

Copyright © 2007 PerkinElmer, Inc.

Produced in the UK.

Trademarks

Registered names, trademarks, etc. used in this document, even when not specifically marked as such, are protected by law.

PerkinElmer is a registered trademark of PerkinElmer, Inc.

FL WinLab is a trademark of PerkinElmer, Inc.

Windows is a trademark of the Microsoft Corporation.

Posidriv is a registered trademark of the Phillips Screw Company.

Contents

Contents.....	3
Warnings and Safety Information.....	7
Safety Information	8
Environmental conditions for safe operation	8
Warning Labels on the Instrument	10
Further assistance.....	11
Introduction	13
About this Manual	14
Conventions	14
Definitions.....	17
Specifications of the LS 55.....	18
Unpacking and Installation	21
Introduction.....	22
Shipping kit list	24
Lifting the LS 55 Luminescence Spectrometer	25
Removal of the shipping clamps.....	26
Electrical Connections.....	29
Connection to electrical mains supply.....	29
Accessory connectors.....	29
Rear panel connectors.....	30
Switching on the LS 55	34
Accessories: Installation and Use	37
Single Position Cellholder (standard)	38
Description	38
Installation and maintenance.....	38
Stirred Single Position Cellholder	39
Description	39
Installation and maintenance.....	39
Operation	39
Stirred Four-Position Cellchanger	40
Description	40
Installation and maintenance.....	40
Biokinetics Accessory.....	41
Description	41
Installation and maintenance.....	41
Operation.....	42
Screw-fitting Flowcell	43
Description	43
Installation and maintenance.....	44
Operation	44
Installing Thermostatting Tubing to Cellholders.....	45
The four-position cellchanger	47

4 . LS 55 User's Guide

Using the Septum Injector	48
Using Stirrer Bars	50
Minimum volumes with various cuvette types.....	51
Semi-micro Cuvette and Holder	52
Description	52
Installation	52
Stirred Semi-micro Cuvette	53
Description	53
Operation	54
Care of Optical Mirrors Inside Cellholder Accessories	55
Resistance to Solvents	56
Sipper.....	57
Description	57
Installation and maintenance	58
Operation	60
LC Flowcell.....	63
Description	63
Installation	63
Operation	65
Front Surface Accessory.....	66
Description	66
Installation and maintenance	67
Operation	70
Using Powders	71
Plate Reader	73
Description	73
Installation	73
Operation	80
The Well Plate Reader application	80
The TLC Scan application.....	81
Measuring TLC plates, gels or other flat samples.....	82
Red-sensitive Detector.....	83
Description	83
Installation	84
Total Emission Accessory	85
Description	85
Installation	85
Operation	86
External Fibre Optic Accessory	87
Description	87
Installation	88
Operation	92
The Fast Filter Accessory	94
Description	94
Installation	96
Operation	104

The Polarizer Accessory	105
Description	105
Installation	106
Bit Switches.....	110
Operation	110
The Low Temperature Accessory.....	111
Description	111
Installation	112
Filling the accessory with liquid nitrogen	117
Operation	118
Removing the accessory.....	119
Accessory spares.....	120
RS232 Commands	121
Introduction.....	122
Section 1- RS232C Communications	125
Monochromator Drive.....	127
Plate Reader Driver	127
Source Control and Photomultiplier Control.....	128
Slit and Filter Motors	128
Analogue Output.....	128
Sample Acquisition Accessories.....	129
Fast Filter Accessory (FFA)	129
Section 2 - Command Formats	131
Monochromator Scan Control Commands	133
Time Drive Commands	136
TLC Scan Commands	139
Data Collection/Processing Set Up Commands	142
Data Output Control Commands	147
Motor Control	148
Calibration Commands	151
Miscellaneous Commands.....	152
Plug-in Accessory Control Commands.....	155
Well Plate Reader (WPR) Commands	157
Fast Kinetics Application (FKA) Commands	158
Fast Filter Accessory (FFA) Commands.....	161
System Description and Maintenance	163
The Optical System	164
The Electronics System and Signal Handling	166
Instrument Modes.....	167
Signal Handling Diagram	170
Fuses	171
Other Fuses.....	172
Removing the Main Cover.....	173
Refitting the main cover	175
Removing the Main Optical Cover.....	176
Refitting the optical cover.....	178

6 . LS 55 User's Guide

Customizing filter wheels	179
Changing the Lamp	181
Preparing the LS 55 for transport	188
Inserting the clamps	188
Lifting the LS 55 Luminescence Spectrometer	191
Removing the clamps	191
Cleaning the LS 55	192
Cleaning the air filter	193
Changing the Instrument Operating Voltage	194
Changing the mains fuse	196
The mains voltage plate	197
Index	199
Index.....	200

Warnings and Safety **Information**

Safety Information

The LS 55 Luminescence Spectrometer has been designed and tested in accordance with PerkinElmer Specifications and IEC 61010-1, 'Safety requirements for electrical equipment for measurement, control and laboratory use'.

This apparatus is protected in accordance with IEC Class 1 rating. This manual contains information and warnings that must be followed by the operator to ensure safe operation and to retain the instrument in a safe condition.

The instrument has been designed for indoor use and will operate correctly under the following conditions:

Ambient temperature 15 °C to 35 °C

Relative humidity 75% maximum, non-condensing

Environmental conditions for safe operation

The LS 55 has been designed to be safe under the following conditions:

- Indoor use.
- Altitude up to 2000 m.
- Temperature range 5 °C to 40 °C.
- Maximum relative humidity 80% for temperatures up to 31 °C, decreasing linearly to 50% relative humidity at 40 °C.
- Mains voltage fluctuations not to exceed 10% of the nominal voltage.
- An IEC Installation Category II (Overvoltage Category II) classification, suitable for connection to local level power supplies.
- An IEC Pollution Degree 2 classification: normally only non-conductive pollution occurs, occasionally, however, a temporary conductivity caused by condensation must be expected.
- An IEC Insulation Class 1 rating for external circuits – only connect equipment that meets the requirements of IEC 61010-1, IEC 60950 or equivalent standards.



WARNING

This equipment must be earthed (grounded).

Any interruption of the protective conductor, inside or outside the instrument, or disconnection of the protective earth terminal is likely to make the instrument dangerous.

When the instrument is connected to the mains supply, terminals may be hazardous when live and the opening of covers or the removal of parts (except those to which access can be gained by hand) is likely to expose live parts. Any adjustment, maintenance and repair of the opened operating instrument must be carried out only by a skilled person who is aware of the hazards involved (a **RESPONSIBLE BODY**). The instrument must be disconnected from all voltage sources before it is opened for any adjustment, replacement, maintenance or repair.

Capacitors inside the instrument may still be charged even if the instrument has been disconnected from all voltage sources. Only fuses with the required current and voltage rating and of the specified type are to be used for replacement. Makeshift fuses must NOT be used and fuse holders must not be short-circuited.

Whenever it is likely that the protection has been impaired, the instrument must be made inoperative and secured against any unauthorized operation. The protection is likely to be impaired, for example, when the instrument:

- Shows visible damage;
- Fails to perform the intended measurement;
- Has been subjected to prolonged storage under unfavorable conditions;
- Has been subjected to severe transport stresses.

NOTE: Using the equipment in a manner not specified in this User's Guide may also impair the protection provided by the equipment.

Warning Labels on the Instrument



Figure 1 Caution label

When the Caution label (Figure 1) is attached to the instrument it means 'Caution, risk of danger'. Refer to this User's Guide to find out the nature of the potential hazard and any actions which have to be taken.

There are three Caution labels on the instrument:

- In the sample area – where the symbol denotes that there is a possibility of eye damage, and you must not stare into the beam in the sample compartment.
- Near the mains inlet fuse – where the symbol denotes that the operator replaceable fuse (see *Fuses* on page 171) is not an IEC fuse, but a CSA approved fuse.
- By the left hand screw that fixes the top cover (at the front left of the instrument) – where the symbol denotes that removing this cover may expose hazardous voltages. Any adjustment, maintenance, or repair of the opened, operating instrument, must be performed by a skilled person who is aware of the hazards involved (a **RESPONSIBLE BODY**).



Figure 2 High voltage label

The high voltage label (see Figure 2) means that removing this cover will give access to hazardous voltages.

There are two High Voltage labels on the instrument:

- Inside the instrument on top of the source cover.
- Inside the instrument on top of the monochromator cover (on the right side of the instrument).

Both these labels mean that the instrument must be switched off, and the mains supply lead removed from its socket before the cover is removed. Any adjustment, maintenance, or repair of the opened, operating instrument, must be performed by a skilled person who is aware of the hazards involved (a **RESPONSIBLE BODY**).

Further assistance

For technical assistance, please contact your local PerkinElmer office or agent, or the address at the front of this manual.



Introduction

About this Manual

This LS 55 User's Guide describes specifications and the installation of the LS 55 Luminescence spectrometer and its accessories.

Information about the FL WinLab Software package can be found in the *FL WinLab Software User's Guide*, which is delivered with the instrument.

Conventions

The following conventions are used in this manual:

- Normal text is used to provide information and instructions.
- **Bold** text refers to text that is displayed on the PC screen.
- UPPERCASE text, for example ENTER or ALT, refers to keys on the PC keyboard. '+' is used to show that you have to press two keys at the same time, for example, ALT+F.
- All eight character 'numbers', for example L2250140, are PerkinElmer part numbers unless stated otherwise.

Notes, warnings and cautions

Three terms, in the following standard formats, are also used to highlight special circumstances and warnings.

<p>NOTE: A note indicates additional, significant information that is provided with some procedures.</p>

**WARNING**

We use the term **WARNING** to inform you about situations that could result in **personal injury** to yourself or other persons. Details about these circumstances are in a box like this one.

D**Warning (Warnung)**

Bedeutet, daß es bei Nichtbeachten der genannten Anweisung zu einer **Verletzung** des Benutzers kommen kann.

DK**Warning (Advarsel)**

Betyder, at brugeren kan blive **kvæstet**, hvis anvisningen ikke overholdes.

E**Warning (Peligro)**

Utilizamos el término **WARNING (PELIGRO)** para informarle sobre situaciones que pueden provocar **daños personales** a usted o a otras personas. En los recuadros como éste se proporciona información sobre este tipo de circunstancias.

F**Warning (Danger)**

Nous utilisons la formule **WARNING (DANGER)** pour avertir des situations pouvant occasionner des **dommages corporels** à l'utilisateur ou à d'autres personnes. Les détails sur ces circonstances sont données dans un encadré semblable à celui-ci.

I**Warning (Pericolo)**

Con il termine **WARNING (PERICOLO)** vengono segnalate situazioni che potrebbero provocare **incidenti alle persone**. Troverete informazioni su tali circostanze in un riquadro come questo.

NL**Warning (Waarschuwing)**

Betekent dat, wanneer de genoemde aanwijzing niet in acht wordt genomen, dit kan leiden tot **verwondingen** van de gebruiker.

P**Warning (Aviso)**

Significa que a não observância da instrução referida poderá causar um **ferimento** ao usuário.

CAUTION

We use the term **CAUTION** to inform you about situations that could result in **serious damage to the instrument** or other equipment. Details about these circumstances are in a box like this one.

D

Caution (Achtung)

Bedeutet, daß die genannte Anleitung genau befolgt werden muß, um einen **Geräteschaden** zu vermeiden.

DK

Caution (Bemærk)

Dette betyder, at den nævnte vejledning skal overholdes nøje for at undgå en **beskadigelse af apparatet**.

E

Caution (Advertencia)

Utilizamos el término **CAUTION (ADVERTENCIA)** para advertir sobre situaciones que pueden provocar **averías graves en este equipo** o en otros. En recuadros éste se proporciona información sobre este tipo de circunstancias.

F

Caution (Attention)

Nous utilisons le terme **CAUTION (ATTENTION)** pour signaler les situations susceptibles de provoquer de **graves détériorations de l'instrument** ou d'autre matériel. Les détails sur ces circonstances figurent dans un encadré semblable à celui-ci.

I

Caution (Attenzione)

Con il termine **CAUTION (ATTENZIONE)** vengono segnalate situazioni che potrebbero arrecare **gravi danni allo strumento** o ad altra apparecchiatura. Troverete informazioni su tali circostanze in un riquadro come questo.

NL

Caution (Opgelet)

Betekent dat de genoemde handleiding nauwkeurig moet worden opgevolgd, om **beschadiging van het instrument** te voorkomen.

P

Caution (Atenção)

Significa que a instrução referida tem de ser respeitada para evitar a **danificação do aparelho**.

Definitions

OPERATOR: Person operating the equipment for its intended purpose.

RESPONSIBLE BODY: Individual or group responsible for the use and maintenance of the equipment and for ensuring that the **OPERATORS** are adequately trained.

Specifications of the LS 55

Principle: Computer controlled ratioing luminescence spectrometer with the capability of measuring fluorescence, phosphorescence, chemiluminescence and bioluminescence.

Source: Xenon discharge lamp, equivalent to 20 kW for 8 μ s duration. Pulse width at half height <10 μ s.

Sample detector: Gated photomultiplier with modified S5 response for operation up to around 650 nm. Red-sensitive R928 photomultiplier can be optionally fitted for operation up to 900 nm.

Reference detector: Photodiode for operation up to around 900 nm.

Monochromators: Monk-Gillieson type monochromators cover the following ranges:

- Excitation 200-800 nm with zero order selectable.
- Emission 200-650 nm with standard photomultiplier with zero order selectable, 200-900 nm with optional R928 photomultiplier.

Synchronous scanning is available with constant wavelength or constant energy difference.

Wavelength accuracy: ± 1.0 nm

Wavelength reproducibility: ± 0.5 nm

Spectral bandpass: The excitation slits (2.5-15.0 nm) and emission slits (2.5-20.0 nm) can be varied and selected in 0.1 nm increments.

Phosphorescence mode: Delay and gate times can be varied to measure phosphorescence. Minimum total period 13.0 ms (50 Hz)

Scanning speed: Scanning speed can be selected in increments of 1 nm for 10-1500 nm/min. Time-dependent data can also be collected.

Emission filters: Computer selectable cut-off (high-pass) filters at 290, 350, 390, 430 and 515 nm, a blank (to act as shutter), a 1% T attenuator and clear beam position.

Sensitivity: Signal to noise is 500:1 r.m.s., using the Raman band of water with excitation at 350 nm, excitation and emission bandpass 10 nm.

Standard cellholder: A single position water thermostatable holder for 10 mm cuvettes.

Supply Voltages: 100 V / 120 V / 220 V / 230 V

Frequency: 50 / 60 Hz

Power: 150 VA

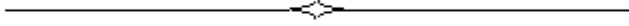

Unpacking and Installation

Introduction

The Model LS 55 Luminescence Spectrometer consists of a spectrometer unit connected to a personal computer (PC). At the front of the Model LS 55 is the sample compartment, which is hinged on the underside. The compartment can be opened by using the finger grip on top of the compartment, as shown in Figure 3, to pull the cover down.



Figure 3 The LS 55

The sample cells are located in the sample compartment; a range of sampling accessories can be installed in this area. Also within the sampling area are two sockets used for controlling accessories that are electrically operated.

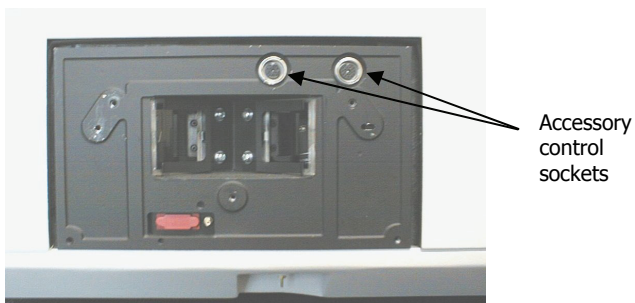

Figure 4 Inside the sample compartment

The Model LS 55 has several other sockets on the rear panel. The electrical mains socket is located on the lower right hand side (viewed from the back) of the rear panel. On the left hand side of the rear panel are an RS232C socket and a terminal block.

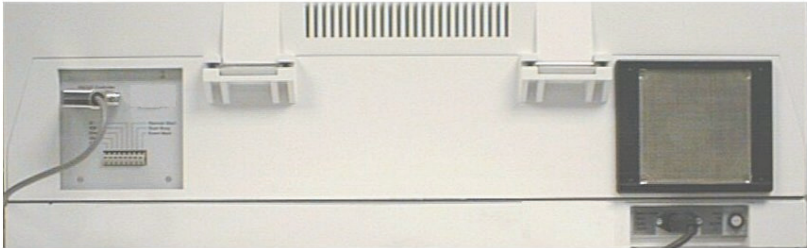

Figure 5 The rear of the LS 55

CAUTION

Do not obstruct the air filter and cooling vents on the rear of the instrument.

Shipping kit list

Part Number	Description
L2255133	Communications cable, LS 45 to PC
L2255142	Analog signal cable
OC973134	Fuse, 250 V T2 A Slo-Blo
OC962348	Fuse, 250 V, 1 AT
04969185	Fuse, 250 V, T100 mA Slo-Blo
04970839	Fuse, 250 V, 2 A Slo-Blo
04967940	Fuse, 250 V, 500 mA Slo-Blo
04960999	Hex key (5/64 AF, for lamp change)
04961071	Spare septa (x3, for septum injector)
04967778	Screwdriver 3/16 inch Blade
04969221	Screwdriver No. 2 Posidriv
L2251286 + L2251287	Septum injector assembly
L2251188	Mains Label 100 V / 220 V

Lifting the LS 55 Luminescence Spectrometer



WARNING

Consult local codes of practice issued by safety advisors before attempting to lift the spectrometer.

As the LS 55 Luminescence Spectrometer weighs approximately 49 kg (approximately 59 kg with packaging), we recommend that the spectrometer is lifted by 2 adults, and that it is lifted by the base of the instrument.

Removal of the shipping clamps

Two clamps are used during shipping of the LS 55 to prevent damage to the monochromators. The clamps are located inside the instrument main cover, and must be removed before switching on the LS 55.

CAUTION

Do not switch on the LS 55 before removing the clamps, or the calibration of one or both monochromators will almost certainly be compromised, resulting in a wavelength failure of 14 nm. This will have to be recalibrated by a service engineer, and is not covered by warranty!

To remove the shipping clamps proceed as follows:

1. Position the LS 55 on the front of the bench so that it overhangs the bench by approximately 8 cm.
2. Undo the two captive screws positioned in recesses underneath the front of the instrument.

There is one on the left side and one on the right side, as shown in Figure 6.

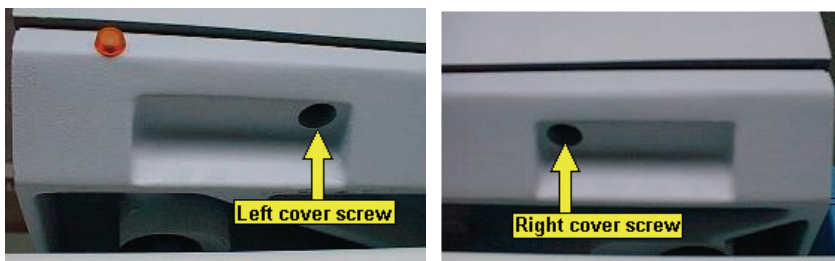

Figure 6 The cover retaining screws

3. Lift the main cover and rest it on the stay, as shown in Figure 7. The shipping clamps are now accessible.

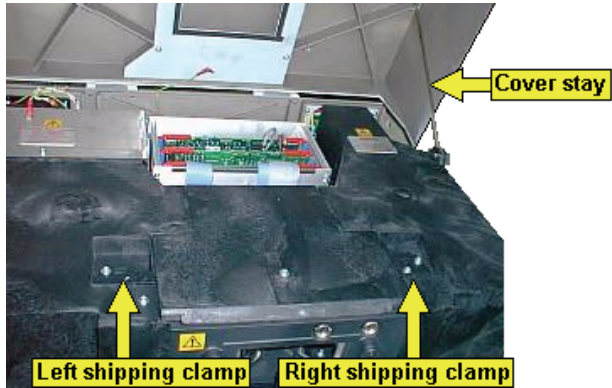

Figure 7 Inside the LS 55

4. Remove the two screws securing one of the clamp plates, as shown in Figure 8.



Figure 8 Shipping clamp screws

5. Lift out the plate.
6. Remove the hexagonal bolt, as shown in Figure 9.



Figure 9 Removing the shipping bolt

7. Turn the clamp plate through 180 degrees so that the hole in the plate no longer lines up with the hole where the bolt was, then replace it, securing it with the two screws removed in step 4, as shown in Figure 10.



Figure 10 Replacing the plate

8. Repeat steps 4 to 7 for the second clamp.
9. Store the two hexagonal clamps in their fixing points on the left side of the instrument, as shown in Figure 11.

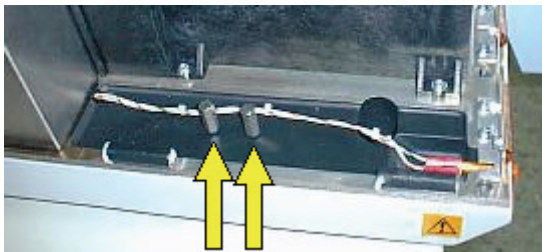

Figure 11 Storing the bolts

10. Lower the instrument cover, close the sample compartment and secure the cover by retightening the two screws loosened in step 2.
11. Slide the instrument back on the bench so that it does not protrude.

Electrical Connections

Connection to electrical mains supply

The mains socket is located on the instrument rear panel, as shown in Figure 12. Ensure that the voltage plate displays the correct voltage setting for the mains supply to be used before plugging the mains lead into the socket. If the correct voltage is not displayed, refer to *Changing the Instrument Operating Voltage* on page 194.



Figure 12 Mains connection and voltage plate

Accessory connectors

Inside the sample area door are two electrical control sockets for accessories, as shown in Figure 13. Note that the left-hand socket has 12 pins and the right-hand socket has 19 pins, so it is not possible to incorrectly connect accessory control plugs. Connecting specific accessories is described in the relevant sections of this manual.

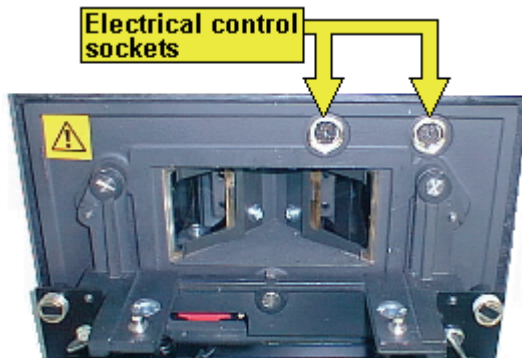

Figure 13 Accessory electrical sockets

NOTE: Remove the two dust covers before connecting accessories.

Rear panel connectors

On the left-hand side of the rear panel (viewed from the back) is a socket labeled **RS232C Controller** and an eight tag terminal block, as shown in Figure 14.

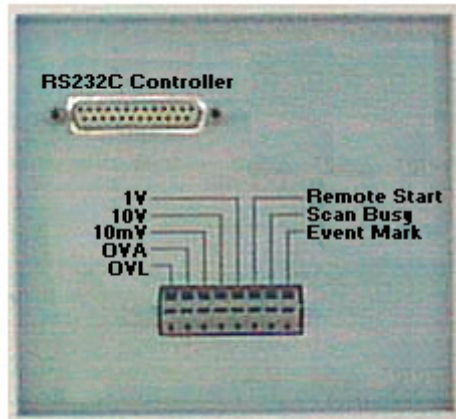

Figure 14 Rear panel electrical connections

The RS232C connection

The RS232C connection is used to communicate with your PC. Connect your LS 55 to your PC as follows:

1. Attach the anti-surge protector to the **RS232C Controller** socket of the LS 55, securing it with the built-in screws.
2. Attach the RS232C cable, supplied, to the anti-surge protector.
3. Attach the 9-pin socket of the RS232C cable to an RS232C socket on the PC. Note which RS232C socket on the PC was used, as this information must be entered during installation of the FL WinLab software.

The Terminal block

The terminal block is used to provide analog signal output from the LS 55, to initiate remote starts and to provide logic status signals for use with intelligent external systems.

To make a connection in the terminal block:

1. Insert a small screwdriver into the bottom of the terminal block and push upwards.
2. Feed the connecting wire into the hole at the top of the terminal block.
3. Remove the screwdriver.
The wire is now firmly clamped.

Analog signal outputs

External signal integration devices, chart recorders, etc., can be connected to the analog outputs. One of the connecting wires (in an unbalanced system having one ground and one signal wire this must be the ground wire) must be connected to the **OVA** connection. The other wire can be connected to the required output, **1V**, **10V** or **10mV**.

Remote starts and event marking

Some FL WinLab software applications can be remotely started on receiving a contact closure between the **Remote Start** and **OVA** connections on the terminal block. For example, if a liquid chromatograph or stopped-flow rapid mixing device is used, then the FL WinLab TimeDrive applications can be automatically started by the device.

Timed event marks can be recorded by supplying a contact closure between the **OVA** and the **Event Mark** connections, or by using the **EVENT** button on the Biokinetic accessory. All FL WinLab software applications which display a **Show Timed Events** option will respond to the contact closure/button press.

Scan Busy

This is a logic level signal, and follows the status of the LS 55:

- during data collection the Scan Busy line is set high.
- on ending the data collection run the logic level reverts to zero.

This function is particularly critical when an external device is attached and the instrument can be started by a Remote Start event. The external device should then monitor the Scan Busy line and not send out a further start signal until the Scan Busy line shows that data collection is complete.

Since this signal is a logic level, devices requiring a contact closure can be connected via a small solid-state relay (with a switching diode for anti-bounce).

Optimal connection to external autosamplers

Some commercially available autosamplers can be programmed to send and receive contact closure signals. Connecting such an autosampler to the LS 55 is straightforward since the LS 55 can be connected via the Remote Start connectors (see *Remote starts and event marking* on page 31). This connection, however, only establishes one-way communication and cannot be considered optimal since the control system is not closed.

Better control can be achieved by making a closed control loop. Use the Remote Start to control the LS 55's measurement and the Scan Busy to control the autosampler. A typical application of such a control system is shown in Figure 15.

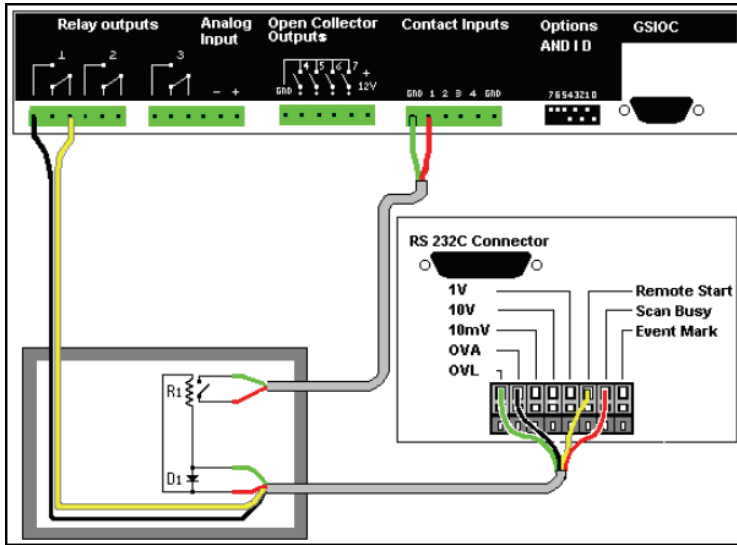

Figure 15 Autosampler control system

NOTE: The use of a solid state relay and anti-bounce signal diode provides the autosampler with status information from the LS 55.

Such a system, if programmed properly in the autosampler, is considered 'closed' since the LS 55 will wait for the autosampler signal before performing a measurement, then the autosampler will wait until the LS 55 has finished being 'busy' before taking the next sample.

Switching on the LS 55

The instrument is switched on and off using the switch on the left-hand side panel of the instrument, as shown in Figure 16.



Figure 16 The power switch



WARNING

Make sure that the power switch on the left side of the instrument is not obstructed. Leave approximately 200 mm gap to allow easy access in case of emergency.

When the instrument is switched on, the neon lamp located on the front lower left-hand side of the instrument is lit.

The LS 55 takes about 1 minute to initialize and should be switched on before the PC. The procedure for switching on is as follows:

1. Before switching on any of the units, ensure that the PC is connected to the LS 55 via the RS232C cable and that both the LS 55 and PC are connected to the electrical mains supply.
As a precautionary measure, a mains surge filter can be used to protect the PC (the LS 55 is very robust and not damaged by typical mains surges). This filter should be used between the mains supply and all components of the LS 55 PC system including the PC, LS 55 and printer.
2. Switch on the LS 55 using the power switch on the lower left-hand side panel. The neon lamp on the lower left-hand side of the LS 55 will light, indicating that the instrument is on.

3. Switch on the PC.
4. When Windows has loaded, start the FL WinLab software.

NOTE: If the instrument has not yet finished initializing, this will be shown on the bottom-right side of FL WinLab Application dialogs. This will automatically reset to **Online** when the system is ready. At this point, data collection can proceed.

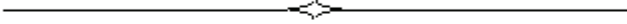

Accessories: Installation and Use

Single Position Cellholder (standard)



Figure 17 Single position cellholder

Description

The standard cellholder (L2250140) delivered with the LS 55 accepts 12.5 mm square (10 mm pathlength) cuvettes, and can be thermostatted using circulated water (as detailed in *Installing Thermostatting Tubing to Cellholders* on page 45).

Installation and maintenance

This cellholder needs no alignment or setting up.

Maintenance consists of routine cleaning of the optical mirrors built into the cellholder block, see *Care of Optical Mirrors Inside Cellholder Accessories* on page 55) and cleaning the base and pressure bar if spillages occur (see *Resistance to Solvents* on page 56).

Stirred Single Position Cellholder



Figure 18 Stirred single position cellholder

Description

The single position stirred cellholder (L2250141) accepts 12.5 mm square (10 mm pathlength) cuvettes, and can be thermostatted using circulated water (as detailed in *Installing Thermostating Tubing to Cellholders* on page 45).

Additionally, a stirrer bar can be inserted into the cuvette to ensure that cells, proteins, etc., remain in suspension. Stirring is also essential for accurate temperature work. Without stirring, temperature gradients of 1 °C can build up within the cuvette. Inert polymer-coated bars are delivered with the accessory (see *Using Stirrer Bars* on page 50).

Installation and maintenance

This cellholder needs no alignment or setting up.

Maintenance consists of routine cleaning of the optical mirrors built into the cellholder block, see *Care of Optical Mirrors Inside Cellholder Accessories* on page 55) and cleaning the base and pressure bar if spillages occur (see *Resistance to Solvents* on page 56).

Operation

The stirrer status (**Low**, **High** or **Off**) can be set by clicking the accessory icon in the LS 55 Status application, as discussed in *Using Stirrer Bars* on page 50.

Stirred Four-Position Cellchanger



Figure 19 Stirred four-position cellchanger

Description

The four-position stirred cellchanger (L2250134) accepts 12.5 mm square (10 mm pathlength) cuvettes, and can be thermostatted using circulated water (as detailed in *Installing Thermostating Tubing to Cellholders* on page 45).

Additionally, a stirrer bar can be inserted into the cuvette to ensure that cells, proteins, etc., remain in suspension. Stirring is also essential for accurate temperature work. Without stirring, temperature gradients of 1 °C can build up within the cuvette. Inert polymer-coated bars are delivered with the accessory (see *Using Stirrer Bars* on page 50). Each position has its own stirrer, so each cuvette can be stirred continuously.

Installation and maintenance

This cellholder needs no alignment or setting up.

Maintenance consists of routine cleaning of the optical mirrors built into the cellholder block (see *Care of Optical Mirrors Inside Cellholder Accessories* on page 55) and cleaning the base and pressure bar if spillages occur (see *Resistance to Solvents* on page 56).

Biokinetics Accessory

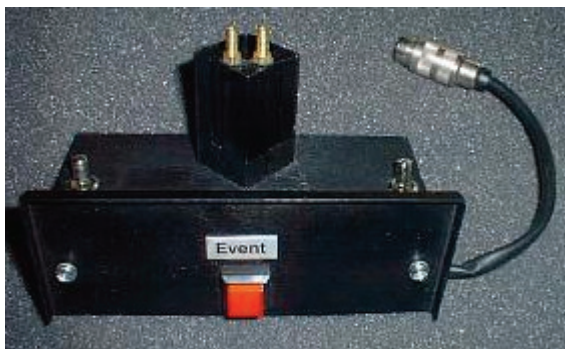

Figure 20 Biokinetics accessory

Description

The Biokinetics accessory (L2250145) is a single position cellholder, which accepts 12.5 mm square (10 mm pathlength) cuvettes, and can be thermostatted using circulated water (as detailed in *Installing Thermostatting Tubing to Cellholders* on page 45).

Additionally, a stirrer bar can be inserted into the cuvette to ensure that cells, proteins, etc., remain in suspension. Stirring is also essential for accurate temperature work. Without stirring, temperature gradients of 1 °C can build up within the cuvette. Inert polymer-coated bars are delivered with the accessory (see *Using Stirrer Bars* on page 50).

Installation and maintenance

This cellholder needs no alignment or setting up.

Maintenance consists of routine cleaning of the optical mirrors built into the cellholder block (see *Care of Optical Mirrors Inside Cellholder Accessories* on page 55) and cleaning the base and pressure bar if spillages occur (see *Resistance to Solvents* on page 56).

Operation

The most important feature of the Biokinetics accessory is the temperature sensor. This is located in the block of the cellholder, and is used to report the temperature of the sample.

NOTE: The sensor should be calibrated using the FL WinLab LS 55 Status application.

FL WinLab applications which display graphical data (Scan, TimeDrive, etc.) automatically record the temperature at the start of data collection in the result dataset header.

The Read application collects intensity, polarization or anisotropy data and saves this as a spreadsheet. If the Biokinetics accessory is fitted, then the temperature is saved simultaneously.

Another important feature is the event marker button on the front plate of the accessory. This is intended for identification of times when reagents are added to the cuvette. In most FL WinLab applications that collect time-dependent data, an option **Show Timed Events** is available. If this option is enabled, when you push the Event button, the Timed Event trace is modified to include a marker.

Screw-fitting Flowcell



Figure 21 Screw-fitting flowcell

Description

The screw-fitting flowcell (B0631133) is intended for automated flow-through, for example using an autosampler.

NOTE: The flowcell is not intended for HPLC, or other high resolution applications (see instead the *LC Flowcell* on page 63).

The flowcell has three main advantages:

- The screw fittings allow tight connections to be made with autosamplers or automated flow systems where high sample throughput requires high reliability due to the unattended nature of data collection. Use the PerkinElmer Flange toolkit, Part number B3000001.
- The internal volume of the flowcell (the internal chamber has dimensions 3x3x10 mm, a volume of 90 μL) is almost perfectly matched to the light beam geometry of the LS 55 (the measured volume is 3x3x9 mm, a volume of 81 μL). This means that this flowcell does not suffer from the sensitivity losses normally associated with flowcells, but gives excellent sensitivity, equivalent to a normal cuvette.
- The flowcell fits into a standard cuvette holder, allowing the flowcell to be thermostatted (as detailed in *Installing Thermostating Tubing to Cellholders* on page 45).

Installation and maintenance

Flowcells are marked with an arrow that indicates the inlet side, as the reagent stream on the inlet side is brought to the bottom of the flowcell, assisting in de-bubbling.

This inlet side should be routed to the sample tube, or to the sampling needle of the autosampler. The outlet side should be routed to the peristaltic pump. An example is shown in Figure 22.

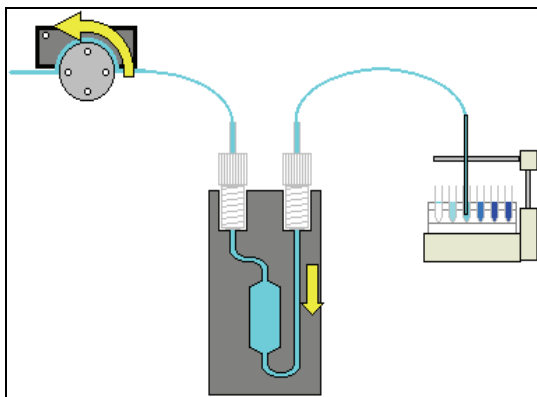

Figure 22 Connecting the flowcell

The system should be cleaned regularly with the solvent used in the analysis. If the system is to be left overnight or longer without being used, then the system should ideally be cleaned with de-ionized water, then with ethanol, then pumped to dryness.

Operation

The inlet and outlet tubing should be installed with screw fittings using the PerkinElmer Flange tool (B3000001). This enables you to fit a wide range of screw fittings to various diameter tubing. Ideally, PTFE or FEP tubing should be used, as this is chemically inert.

NOTE: The internal diameter of the tubing is important, too small a diameter could lead to inefficient pumping and cavitation, producing air bubbles. Too large a diameter will lead to large sample volumes. Typical internal diameter is 0.7-1.0 mm.

Installing Thermostating Tubing to Cellholders

All cuvette holders supplied for use with the LS 55 are thermostatable using circulating water:

- The cuvette holders are made watertight with a sealant that is guaranteed up to 60 °C.
- Higher temperatures may make the sealant leak, in which case you should replace it with a suitable sealant with higher temperature specification.
- At temperatures below 15 °C, condensation may occur on the surfaces of the cuvette. If this is the case, either purge the sample area with dry air, or lead dry air onto the cuvette surfaces using tubing.

To fit the thermostating tubing:

1. Route the tubing into the sample area and onto the two tubing ports under the sample area door, as shown in Figure 23.

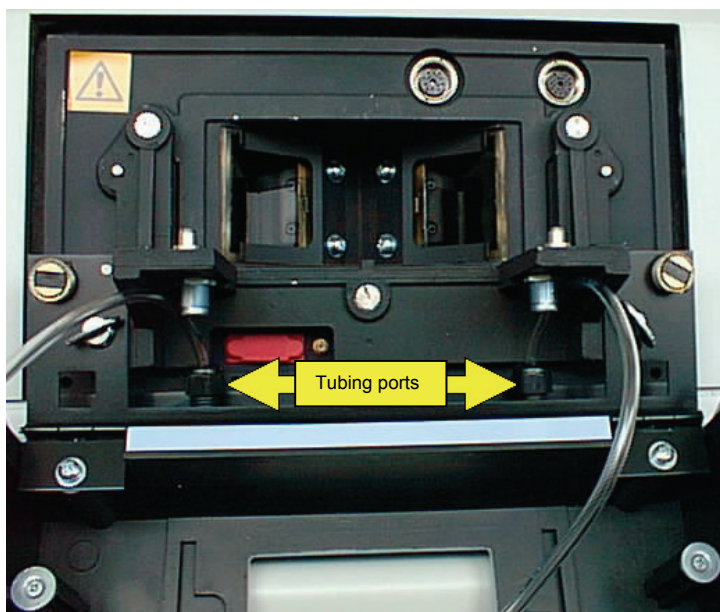

Figure 23 Tubing ports

2. The tubing is then brought around the outside of the accessory bracket, as shown in Figure 24.

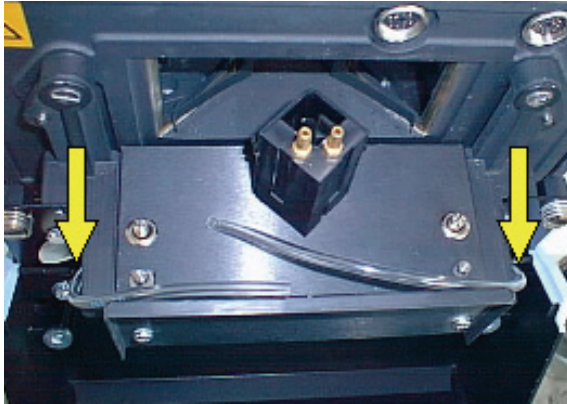

Figure 24 Routing the tubing

3. Attach the tubing to the cellholder nozzles and secure with cable ties or clamps, as shown in Figure 25.

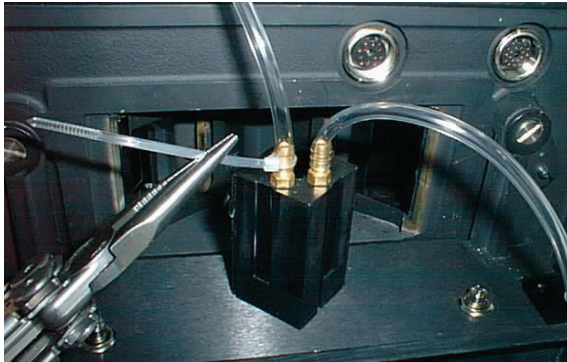

Figure 25 Attaching the tubing to the cellholder

The four-position cellchanger

Installing tubing for the four-position cellchanger is slightly more complicated:

1. Disconnect the cellchanger, so it can be turned manually.
2. Turn the cellchanger to appear as shown in Figure 26.

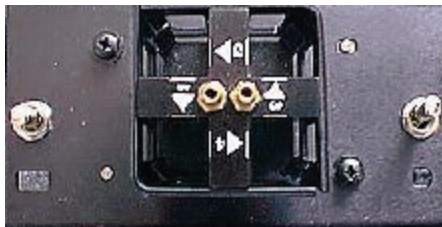

Figure 26 Positioning the cellchanger

3. Install the tubing.
This will ensure that the tubing will only turn through a maximum of 135 degrees during operation.

CAUTION

If the tubing is installed with the cellchanger at position 1, the tubing turns through 270 degrees, putting greater strain on the stepper motor, leading to potential step failures.

Using the Septum Injector



Figure 27 The septum injector

The LS 55 is delivered with a septum injector accessory. This locates on top of the sample area door, and guides a syringe needle into the cuvette.

To install the septum injector:

1. Place a septum into the injector barrel (L2251286) and push the cap (L2251287) into the barrel, trapping the septum, as shown in Figure 28.

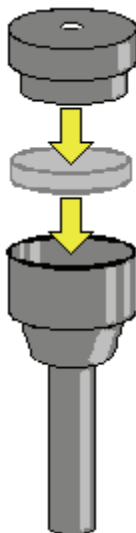

Figure 28 Assembling the septum injector

2. Check that the cap fits securely.
If not, the septum is probably too thick to allow the cap to grip the barrel adequately, and should be replaced.
3. Remove the blanking plug from the LS 55 sample area door, as shown in Figure 29.

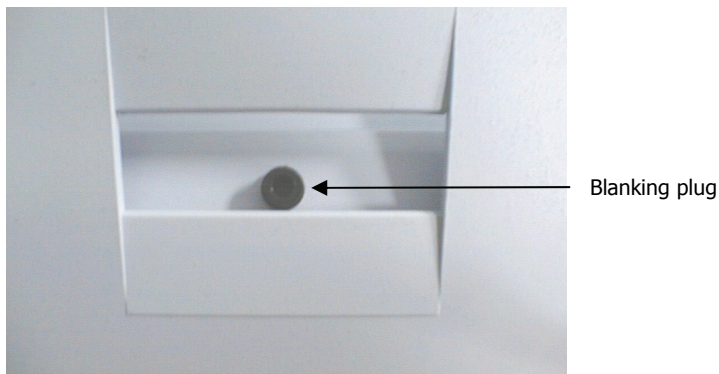

Figure 29 The blanking plug

4. Insert the septum injector.

NOTE: The distance between the top of the cuvette and the bottom of the injector barrel avoids the thermostating tubing fouling the injector when the door is closed. For this reason, a short syringe needle will not reach the cuvette, and there is no guarantee that injected reagents will enter the cuvette. A minimum syringe needle length of 70 mm is required to ensure that the needle enters the cuvette.

Using Stirrer Bars

Several accessories feature built-in stirring mechanisms.

It is intended that stirring is performed in a cuvette supplied by PerkinElmer. These cuvettes are completely optically flat on all surfaces, including the base, allowing the stirrer bar to freely rotate, whereas certain disposable cuvettes, made of polystyrene or a similar polymer, have curved internal bases from the molding process. This can cause severe physical disturbance of the rotation of the stirrer, such that the stirrer cannot rotate at all or it rotates very erratically. In this case, it is best to use a flat, round stirrer with a cross or vane built into the top. This type of stirrer is more stable, and can rotate on an uneven surface.



PerkinElmer cuvette



Polymer cuvette



Special stirrer

Figure 30 Stirrers in cuvettes

The stirrer is controlled using the FL WinLab LS 55 Status application, by clicking the accessory icon. Three speeds can be set:

- **Off** - no stirring.
- **Low** - intended for keeping sensitive cells in suspension without physical damage.
- **High** - intended for keeping the sample suspended (or the temperature homogeneous) where the sample will not be physically damaged by the grinding action between the stirrer and the bottom of the cuvette.

NOTE: High speed is not intended for rapid mixing within the cuvette as stirrer speeds high enough to effect rapid mixing often cause a vortex to be created, producing bubbles in the light beam and high and erratic background levels.

Minimum volumes with various cuvette types

It is often desirable to minimize the volume of reagents used in the cuvette. This can be done using a smaller internal pathlength cuvette, with or without a stirring chamber underneath.

It should also be noted that cuvettes do not have to be totally filled, the liquid only has to cover the entire height of the light beam.

NOTE: However, failure to cover the height of the beam will cause light to be scattered off the underside of the meniscus, producing very high background signals.

The excitation light beam is 9 mm high in the center of the cuvette. The center of the excitation beam is 13.5 mm from the base of the cuvette:

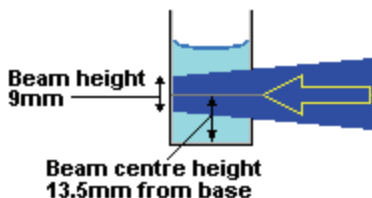

Figure 31 Position of the beam through a cuvette

In a 1 cm² cuvette, for example, the liquid has to fill the cuvette to a level of 2 cm (2 ml of liquid) in order to avoid light scattering by the meniscus.

Some users place a spacer block (up to 8 mm thick, at this thickness allowing 800 μ L less volume) under the cuvette to raise it, eliminating the unmeasured volume beneath the light beam. In principle this is acceptable, the notable exception being that if a stirrer is being used, then the spacer would reduce the magnetic coupling between the stirrer coils and stirrer bar to almost zero and the stirrer bar will not turn.

Semi-micro Cuvette and Holder



Figure 32 The semi-micro cuvette assembly

Description

The semi-micro cuvette and holder (L2250139) enables you to measure smaller samples than with a standard cuvette. In spite of the decreased volume, however, sensitivity is not compromised since the LS 55 has a measured volume of 3 x 3 x 9 mm, which is smaller than the semi-micro cuvette's internal 5 mm pathlength.

Installation

The holder is simply inserted into a standard cellholder, as shown in Figure 33.

NOTE: The lip at the top, for removal of the holder, must be aligned away from you so that the lip does not contact the thermostating nozzles, which would stop the holder from sitting properly in the cellholder.

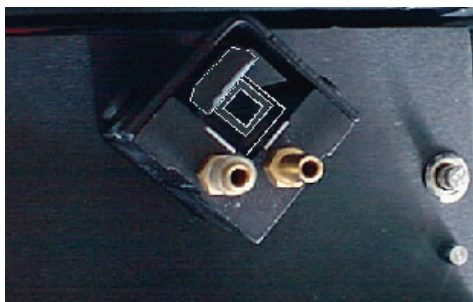

Figure 33 Inserting the semi-micro cuvette

Stirred Semi-micro Cuvette



Figure 34 The stirred semi-micro cuvette

Description

Micro and semi-micro cuvettes, which allow the user to measure smaller sample volumes than standard 1cm pathlength cuvettes, typically have disadvantages in that stirring and thermostating are difficult to achieve.

In the case of stirring, this is either because the internal dimensions of the microcuvette are too small or because the small size of the stirrer for cuvettes with 5 mm pathlength do not function efficiently.

Thermostating is difficult due to the use of a semi-micro cuvette adaptor, which fits into the standard cuvette holder and accepts the smaller cuvette. These adaptors are normally manufactured from polymer material, which is an effective thermal insulator.

The stirred semi-micro cuvette (B0631132) overcomes both of these problems:

- The outside dimensions are the same as for a 1 cm cuvette, giving good contact with the cellholder for thermostating (as detailed in *Installing Thermostating Tubing to Cellholders* on page 45), but the internal dimensions are smaller for decreased sample volume.
- At the base of the cuvette there is a chamber for insertion of a standard stirrer.

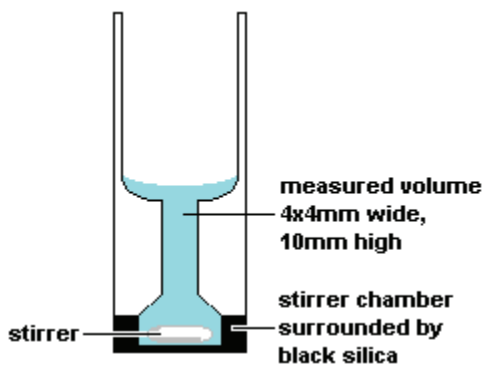

Figure 35 Cross-section of the stirred semi-micro cuvette

Operation

The stirrer is controlled using the LS 55 Status application in the FL WinLab software, as discussed in *Using Stirrer Bars* on page 50.

Care of Optical Mirrors Inside Cellholder Accessories

The mirrors built into cellholder accessories are used to reflect unabsorbed excitation light back into the sample to give a second pass at exciting the sample.

The emission mirror collects a portion of light emitted away from the instrument and reflects it back into the instrument.

Both mirrors together provide a 2.5-fold increase in signal, so in the worst case if both mirrors are totally corroded, they will not reflect light and the signal will decrease by a factor of 2.5-fold.

Additionally, if fluorescent material is allowed to build up on the mirrors, then background levels will increase significantly.

To prevent these possibilities, the mirrors should be regularly cleaned with methanol or a non-corrosive solvent.

Resistance to Solvents

The base of the cuvette holder block is manufactured from Delrin, a reasonably inert polymer. This is done to effect thermal isolation from the baseplate of the accessory for thermostating. Although Delrin is resistant to most solvents, it can still be attacked by particularly aggressive solvents and acids such as 0.1 M perchloric acid.

The pressure bar which presses the cuvette back into the mirrored corner of the cuvette is also manufactured from Delrin.

To prevent damage, spillages should be washed with non-corrosive solvent or methanol.

If the base becomes attacked, the consequences are not severe unless it is totally dissolved, in which case the cuvette can fall through the base of the holder onto the metal baseplate. If the pressure bar is attacked, then the cuvette will not be located as firmly on the rear surfaces of the cellholder, possibly leading to unreproducible signals.

Sipper

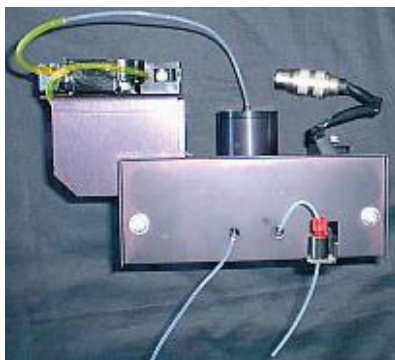

Figure 36 The Sipper accessory

Description

The Sipper accessory (L2250135) is used to increase sample throughput, either by itself or in conjunction with an external autosampler.

The Sipper consists of a flow cell coupled to a peristaltic pump. When used without an autosampler, sampling is initiated by putting the sample container under the tube, lifting the container so that the tube goes into the sample and then raising it further until a microswitch is activated which starts the pump, as shown in Figure 37. The sample is then pumped into the flowcell and measured.

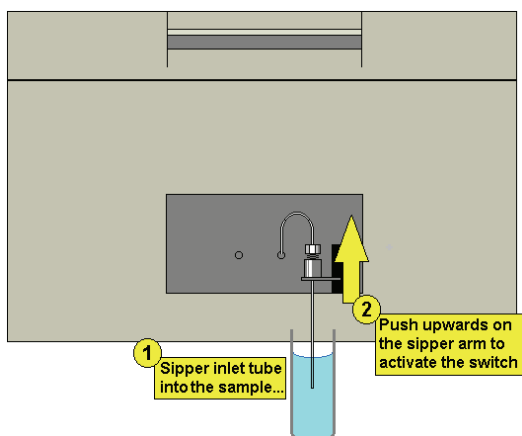

Figure 37 Using the Sipper

The measured volume of the sipper flowcell is approximately 1.5 x 1.5 x 10 mm. The maximum measured volume of the LS 55 (with wide open excitation and emission slits) is approximately 3 x 3 x 10 mm, so the absolute sensitivity when using the Sipper accessory would be around a factor of 4 times less sensitive than when using a cuvette. In spite of this loss, the Sipper accessory represents a much more sensitive option for high sampling throughput than for example a plate reader, where sensitivity would be at least a factor of 20 less sensitive (even for dedicated plate reader instruments).

Installation and maintenance

The Sipper accessory must be aligned before use, to ensure that the center of the flowcell sits correctly at the optical focus of the LS 55. Installation is carried out as follows:

1. If the tubing is clamped in the switch lever, loosen the tubing clamp screw, as shown in Figure 38, and pull out the tubing.

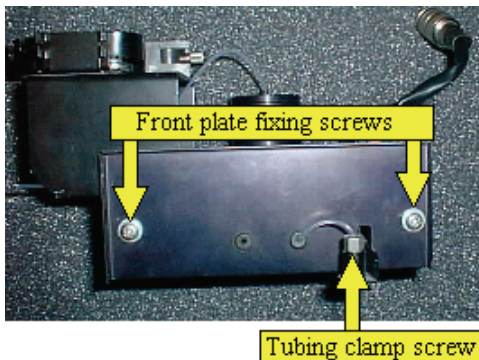

Figure 38 The front of the Sipper

2. Loosen the two front plate fixing screws, as shown in Figure 38, and remove the front plate.
3. Loosen the two mount plate locking screws, as shown in Figure 39. This enables the mount plate to move freely during alignment.

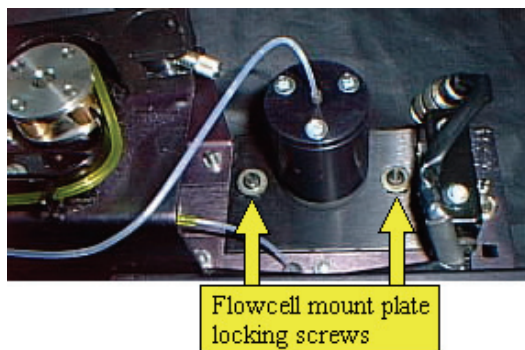

Figure 39 The mount plate

4. Fix the Sipper to the LS 55 accessory bracket and lock it into place by pressing the two quick release fasteners.
5. Insert the accessory cable into the right-hand accessory socket inside the sample area.
6. Ensure that the tubing is connected, and that the peristaltic pump tubing is correctly held in the pump cam/roller assembly.
7. Turn the pressure block pin carrier until the pressure pin latches into its bracket, as shown in Figure 40.

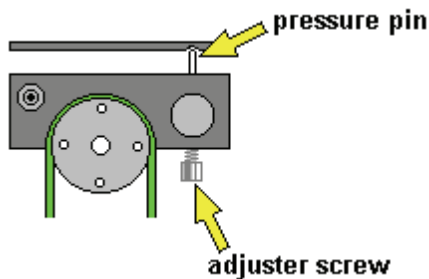

Figure 40 Pressure pin and adjuster screw

8. Tighten the adjuster screw, as shown in Figure 40, until sufficient pressure is applied to the pump tubing to enable the sipper to pump efficiently.

NOTE: When the sipper is correctly installed it needs no priming, as it will pump from dry.

9. Pump a fluorescent sample into the Sipper.

10. Start a TimeDrive using suitable wavelengths for the fluorescent dye used, using slit widths of 10 nm (excitation) and 5 nm (emission).
Duration should be 2-3 minutes.
11. During data collection, adjust the two (1/8") Hex screws shown in Figure 41 until the maximum signal is observed.

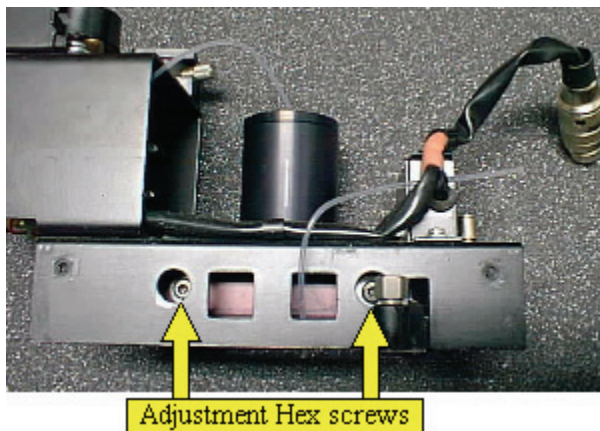

Figure 41 Adjustment screws

12. Remove the accessory from the LS 55 sample area and tighten the locking screws shown in Figure 39.
13. Re-fit the front plate, as shown in Figure 38.
14. Re-insert and re-clamp the tubing using the tubing clamp screw, as shown in Figure 38.

Operation

The Sipper accessory can be controlled manually using the LS 55 Status application. The Scan and Concentration applications include full sipper control. The Sipper parameters (pump time, wait time, purge time and direction) are set in the application so that when the Sipper is started by pushing the Sipper arm upwards, sampling and measurement are automatically triggered.

Manual control

1. Start the **LS 55 Status** application from the FL WinLab software.



2. Click the Sipper icon in the LS 55 Status application.

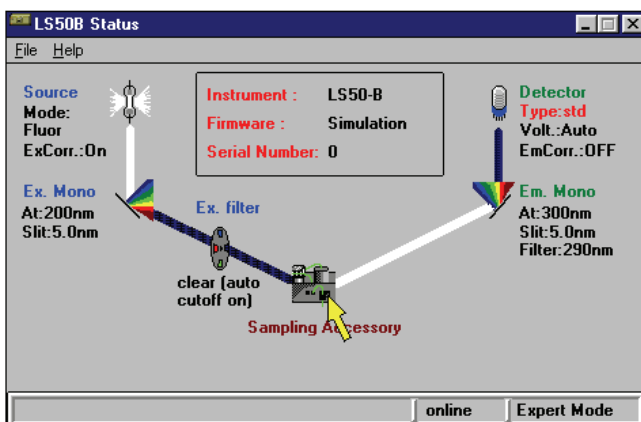

3. Select whether to **Pump Forwards** or to **Pump Reverse**, enter the required **Pump Time** (in seconds) and click **Sip**.

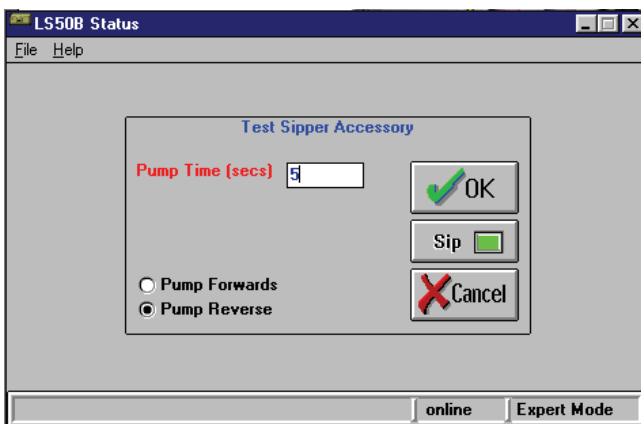

Scanning spectra

1. In the **Scan** application, select the kinetic scan option.

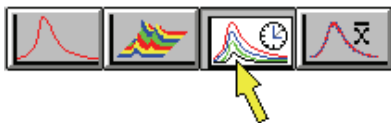

2. Set up the kinetic scan parameters panel as required.

Kinetic Scan Range Parameters			
Number of scans:	<input type="text" value="50"/>	<input type="radio"/>	Repeat with time
<input checked="" type="checkbox"/> Sip	Time (s): <input type="text" value="8,5"/>	<input type="radio"/>	Repeat on User Prompt
	Delay (s): <input type="text" value="1,0"/>	<input type="radio"/>	Repeat on External Contact
<input type="checkbox"/> Auto lamp off	<input type="text" value="0,0"/>	<input checked="" type="radio"/>	Repeat on Sipper Contact
			Delay before meas.(s)

Now, when you start a scan by clicking on the green traffic light, the system will wait for the Sipper switch to be activated. The sample will then be pumped into the flowcell and the spectrum measured. The system will wait again for the Sipper switch to be activated for the next spectrum. When all spectra have been measured, a 3D file will be created which can be viewed by selecting **3D Viewer** on the Data Handling menu in FL WinLab.

Routine quantitation with the Concentration application

1. In the **Concentration** application, select Setup parameters and set up the sipper panel as required.

The example here will sample for 6 seconds, wait 1 second for de-bubbling, measure the intensity then return the sample for 9 seconds.

Sipper on <input checked="" type="checkbox"/>	Pump time (s)	<input type="text" value="6,0"/>	<input type="radio"/>	purge forwards
	Delay time (s)	<input type="text" value="1,0"/>	<input checked="" type="radio"/>	purge backwards
	Purge time (s)	<input type="text" value="9,0"/>		

3. Select User info and set up the Options panel as required.

Options:	<input checked="" type="checkbox"/> Automatic run	<input type="checkbox"/> allow intensity edit
	<input type="radio"/> Keyboard Start	
	<input type="radio"/> Remote Start	
	<input checked="" type="radio"/> SipperStart	

Measurement of references and unknown samples is performed as normal, except that the system will wait for the user to insert the sipper inlet tube into the sample vial and activate the sipper switch.

LC Flowcell



Figure 42 The LC Flowcell

Description

The LC Flowcell accessory (L2250138) enables you to collect chromatographic data using the LS 55. The flowcell has internal dimensions of 1.5 x 1.5 x 10 mm (measured volume approximately 20 microlitres) and is manufactured from synthetic fused silica, giving optical performance down to 200 nm.

Inlet and outlet tubes are made of an inert polymer material (FEP) which ensures biocompatibility.

NOTE: FEP tubing has low structural strength and thus poor resistance to back pressure, so care should be taken when placing the LS 55 with LC Flowcell into a series of detectors. The LS 55 should be located at the end of the chain to reduce back pressure.

Installation

The LC Flowcell accessory must be aligned before use, to ensure that the center of the flowcell sits correctly at the optical focus of the LS 55:

1. Loosen the two front plate fixing screws and remove the front plate, gently feeding the inlet and outlet tubes through the grommets on the front plate, as shown in Figure 43.

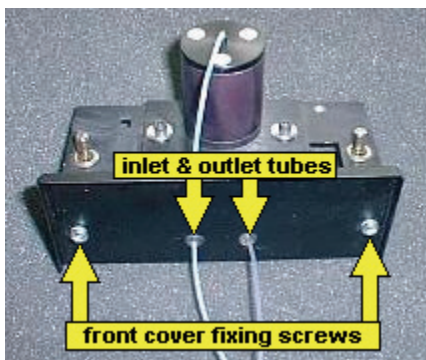

Figure 43 Fixing screws and tubing

2. Loosen the two mount plate locking (1/8") hex screws.
This enables the flowcell mount plate to move freely during alignment.

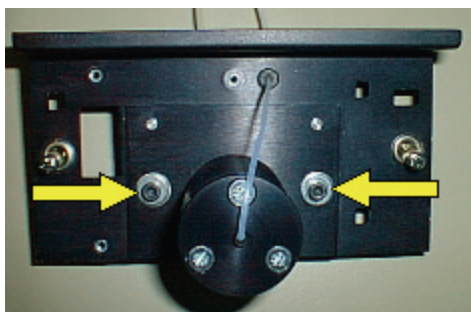

Figure 44 Mount plate locking screws

3. Affix the LC Flowcell accessory to the LS 55 and lock it into place by pressing the two quick release fasteners.
4. Connect the syringe supplied to the inlet tube.
5. Pump a fluorescent sample into the flowcell until the liquid emerges from the outlet tube, checking by eye that there are no air bubbles trapped in the LC Flowcell.
6. Start a TimeDrive using suitable wavelengths for the fluorescent dye used, using slit widths of 10 nm (excitation) and 5 nm (emission).
Duration should be 2-3 minutes.
7. During data collection, adjust the two (1/8") Hex screws shown in Figure 45 until the maximum signal is observed.

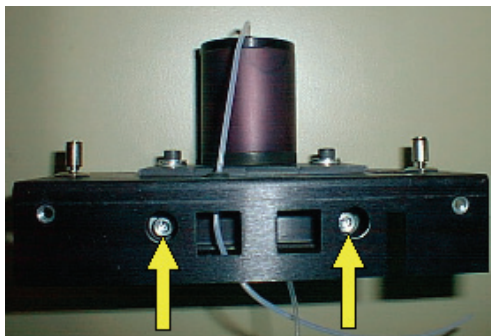

Figure 45 Adjustment screws

8. Remove the accessory from the LS 55 sample area and tighten the locking screws shown in Figure 44.
9. Carefully feed the inlet and outlet tubes through the grommets on the front cover plate then re-secure the front cover plate using the two screws, as shown in Figure 43.

Operation

Data collection for the LC Flowcell is made using the TimeDrive application. Data collection can be synchronized with a signal from an HPLC pump using contacts on the LS 55's rear panel (see *Remote starts and event marking* on page 31).

Front Surface Accessory



Figure 46 The Front Surface accessory

Description

The Front Surface accessory (52123130) is used for the measurement of powders and flat samples such as papers, leaves, polymers, etc. It is also used in the life sciences for turbid samples where the sample cannot be diluted but gives severe quantitative problems due to light scattering.

The Front Surface accessory must be aligned to ensure correct sensitivity. Failure to do this could lead to a large loss of sensitivity. Furthermore, the process of alignment optimizes sensitivity to luminescence signals and minimizes the effect of light scattering.

Installation and maintenance

1. Remove the two screws that hold the fascia and front panel, as shown in Figure 47.

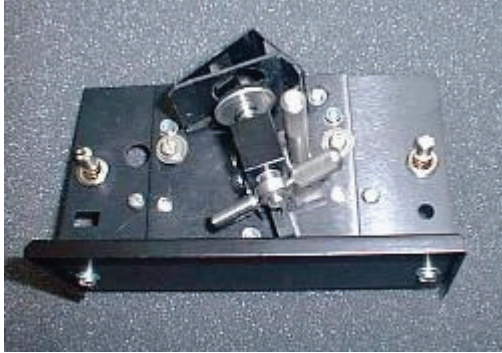

Figure 47 Front bolts

2. Refit the front plate without the fascia, as shown in Figure 48.

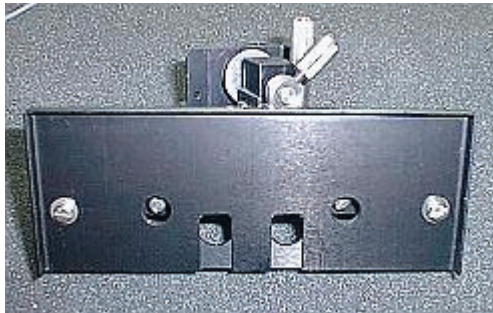

Figure 48 Front plate without fascia

3. Loosen the two upper clamping screws, as shown in Figure 49.



Figure 49 Upper clamping screws

4. Loosen the three screws on the underside of the accessory, as shown in Figure 50.

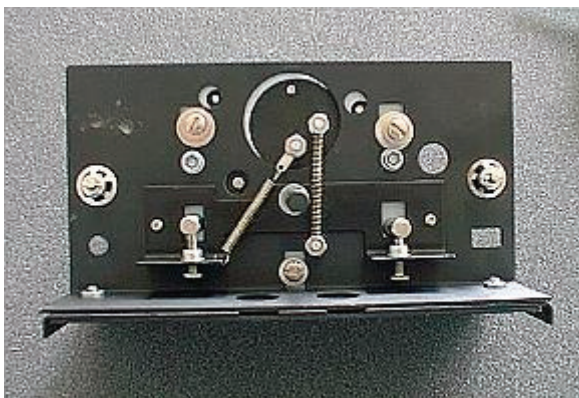

Figure 50 The screws underneath the accessory

5. Fit the accessory to the LS 55 using the two cam-lock fasteners.
6. Mount a flat fluorescent sample in the Front Surface accessory (see *Operation* on page 70).
A business card is useful for this purpose as most are highly fluorescent, and the card is strong enough to remain flat during clamping.
7. Start a TimeDrive from the FL WinLab software, using suitable parameters.
For a business card, these would be:
Excitation wavelength 300 nm
Emission wavelength 550 nm
Slits 10/2.5 nm or 10/5 nm (Excitation/Emission)

8. Using the LS 55 Status application, click the emission monochromator icon and select emission filter = 1% T attenuator.
9. Using a flat screwdriver, turn the two adjustment screws shown in Figure 51, to optimize the signal.
During the run it may be necessary to click the Autoexpand Y-axis toolbar button if the signal goes off-scale.

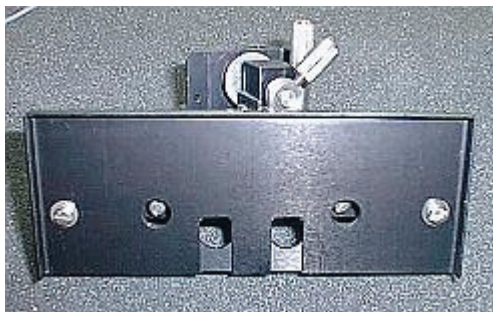

Figure 51 Adjustment screws

NOTE: If the signal exceeds 999.999, then the run will have to be stopped and more attenuation or narrower emission slit width used.

10. When the maximal signal has been reached, stop the run and remove the accessory from the LS 55.
11. Tighten the two upper locking screws, as shown in Figure 49, and the three locking screws underneath the accessory, as shown in Figure 50.
The alignment will now remain constant.
12. Remove the two screws from the front plate and refit the front plate with fascia, as shown in Figure 47.
13. Re-fit the accessory to the LS 55 using the two cam-lock fasteners.

Operation

There are two adjustable parts in the Front Surface accessory, these allow the measurement of samples with varying thickness.

The plunger plate is spring loaded, the stroke of the spring action is controlled by a metal ring, locked by a horizontal screw, as shown in Figure 52. The plunger plate is pulled back to allow insertion of the sample.

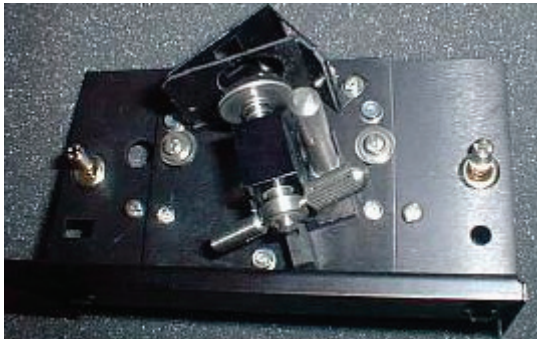

Figure 52 The plunger

Coarse movement of the plunger plate is achieved by moving the plunger base itself. This moves linearly and is locked by a large, vertical screw.

1. Unlock the vertical screw, as shown in Figure 52, and pull the plunger plate back.
2. Insert the sample so that it rests against the measurement baffle.
3. Push the plunger plate forwards so that some pressure is applied to the plunger plate to hold the sample in position.
4. Lock the vertical screw.

You replace the sample by pulling back the plunger plate.

Using Powders

The powder accessory can be used to measure powders or flat samples which are too small to be held in the accessory's window.

The sample should be as finely powdered and as homogenous as possible to avoid surface structure effects. Also, the vertical excitation light beam image is 9 mm high and 3 mm wide, so the sample should fill the center of the window at least to fill this area (if in doubt, set the excitation monochromator to a visible wavelength such as 550 nm and observe the relative locations of the light area and the sample).

For the measurement of oils or very viscous samples, the sample can be sandwiched between two silica windows.

1. Unscrew the base plate from the Powder holder and add the sample onto the silica window, as shown in Figure 53.

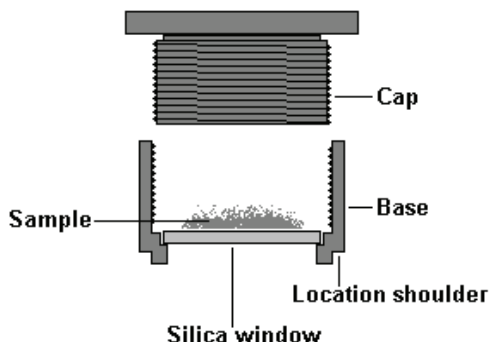

Figure 53 The powder accessory

2. Replace the cap and screw it home until the sample is held tightly.
3. Place the powder holder into the Front Surface accessory checking that the location shoulder fits into the window of the accessory's measurement baffle. If the shoulder does not fit, then the hole in the baffle should be enlarged suitably with a round file.

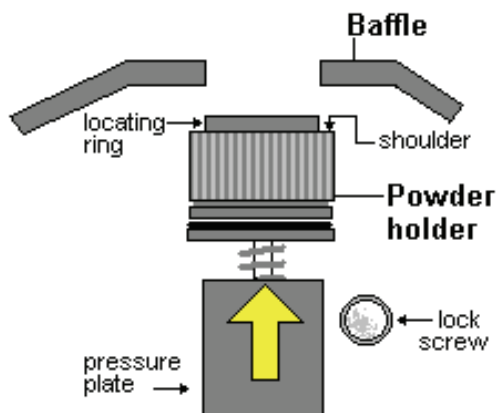

Figure 54 Using the powder accessory

Plate Reader



Figure 55 The Plate Reader

Description

The Plate Reader accessory (L2250140) attaches to the front of the LS 55 and can be used to measure microplates or scan any flat sample up to a measurement area of 128 mm x 96 mm.

Measurement of microplates can use a wavelength program of up to 20 wavelength parameter sets, in addition the measurement can be automatically repeated for kinetics.

Microplate measurement results in the creation of a data spreadsheet. Flat sample measurement creates a 3D datafile that can be viewed using the 3D Viewer included with FL WinLab.

Installation

Before use, the Plate Reader must be correctly installed. This involves optical alignment of the Plate Reader accessory and the creation of a Plate Format file, so that the FL WinLab software can measure in the correct locations on the microplate.

In order to perform the optical alignment, a small (~4 cm square) flat mirror and a dentist's mirror should be used.

1. Open the LS 55 top cover, as described in *Removing the Main Cover* on page 173.

2. Switch off the HT supply to the photomultiplier, as shown in Figure 56.

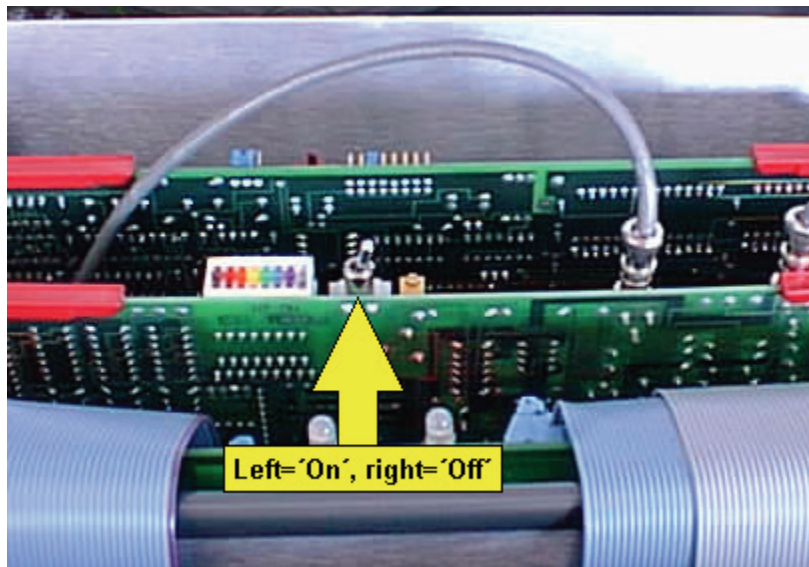

Figure 56 HT switch for the photomultiplier

3. Open the sample area accessory cover and remove the existing sampling accessory by pressing on the 2 quick release fasteners.
4. Undo the three screws which attach the sample accessory bracket to the LS 55, as shown in Figure 57.

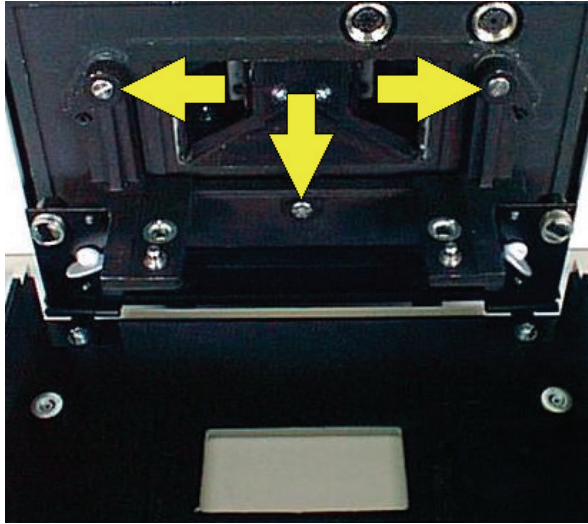

Figure 57 Sampling accessory bracket screws

5. Unscrew the two fixing screws and remove the optical assembly, as shown in Figure 58.

This is so that the sharp square edges at the front of the optical assembly cannot accidentally break the LS 55's optical windows during fitting.

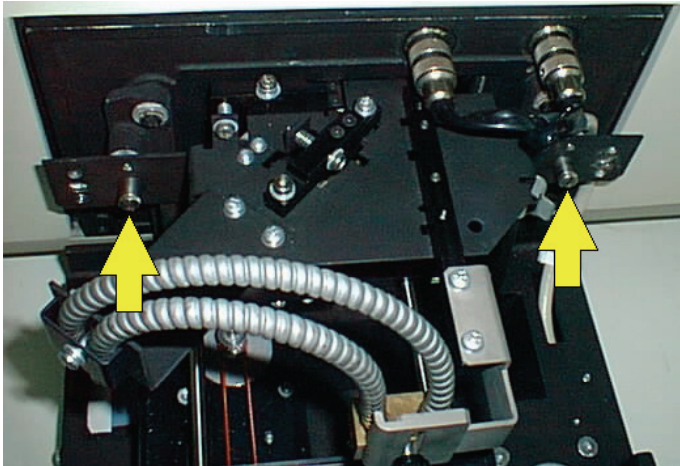

Figure 58 Optical assembly screws

6. Fix the plate reader body to the LS 55 by aligning the steel dowels, as shown in Figure 59.

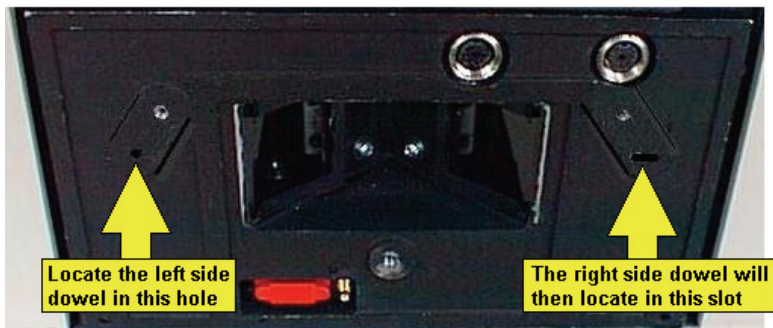

Figure 59 Locating dowels

7. Tighten the three screws that secure the Plate Reader to the LS 55, as shown in Figure 60.

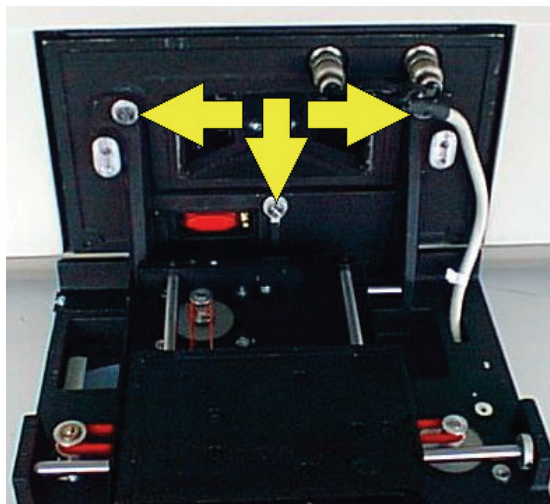

Figure 60 Plate Reader screws

8. Attach the optical assembly to the Plate Reader and tighten the two screws which secure it, as shown in Figure 61.

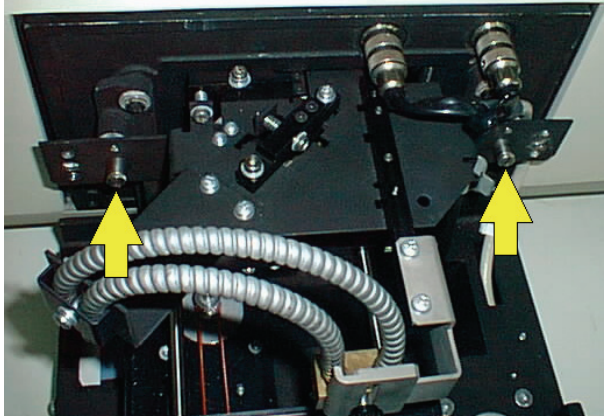

Figure 61 Attaching the optical assembly

9. Using the LS 55 Status application, set the excitation wavelength to 0 (zero order, white light) to assist in alignment.
10. Insert the dentist's mirror between the LS 55 front plate and the optical assembly.
The idea is to observe the excitation fibre to ensure that the excitation light falls directly on the fibre bundle, optimising light throughput.
11. Loosen the excitation fibre locking screw, as shown in Figure 62.

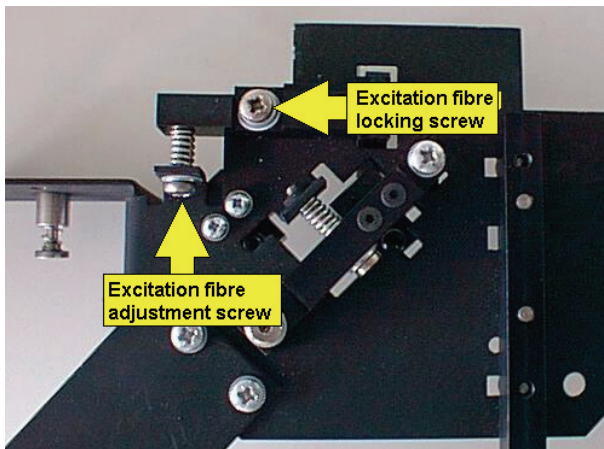

Figure 62 Excitation fibre screws

12. Rotate the mirror via the adjustment screw, as shown in Figure 62, until the light image is centralized on the fibre bundle, as shown in Figure 63.

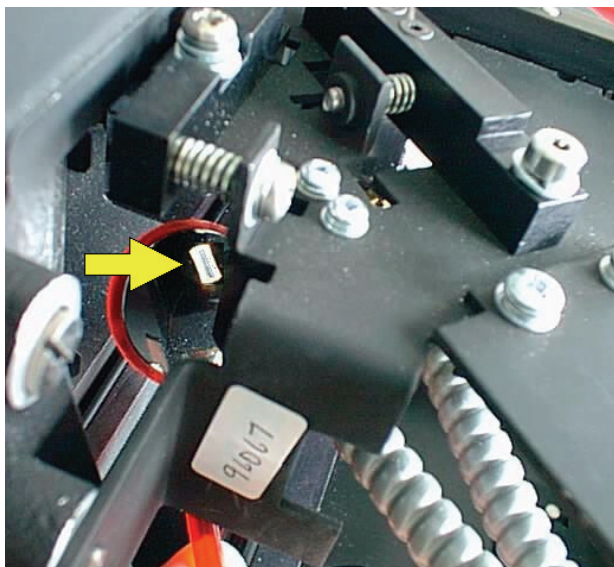

Figure 63 The end of the fibre bundle as seen in the dentist's mirror

13. Tighten the locking screw.
14. Open the LS 55 main cover as detailed in *Removing the Main Cover* on page 173.
15. Remove the main optical cover as detailed in *Removing the Main Optical Cover* on page 176.
16. Switch off the room lighting.
This enables you to see the emission entrance slit easier.
17. Set the excitation wavelength to zero order.
This produces white light.
18. Set the emission slit width to 10 nm.
19. Place a plane mirror beneath the fibre optic sampling end.
This reflects the white light back into the instrument, for alignment purposes.
20. Observe the emission entrance slit through the open aperture in the emission filter wheel, as shown in Figure 64.

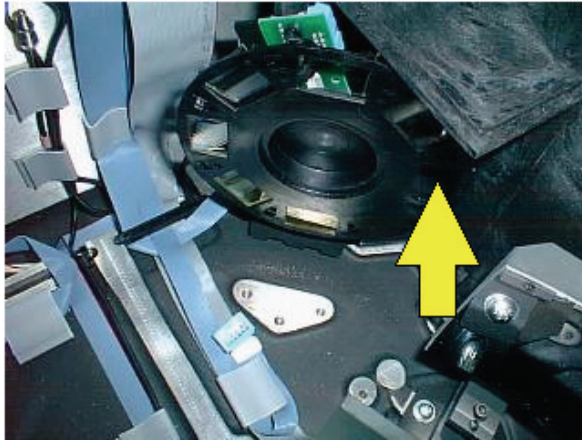

Figure 64 Position of the emission entrance slit

21. Loosen the emission fibre locking screw, as shown in Figure 65.

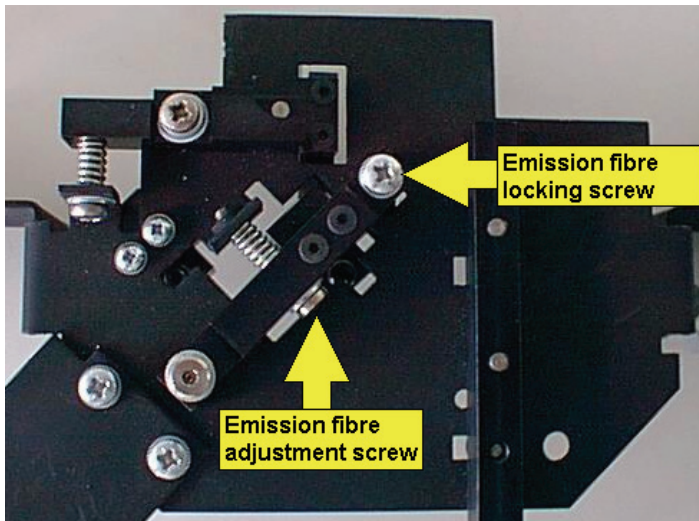

Figure 65 Emission fibre screws

22. Turn the adjustment screw until the white light is centralized on the emission slit inside the LS 55, as shown in Figure 66.

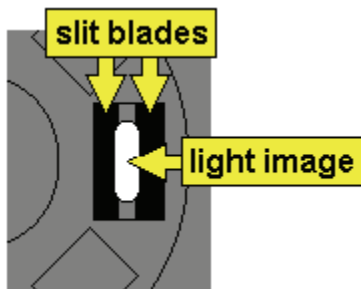

Figure 66 Aligning the emission fibre

23. Tighten the emission locking screw.

NOTE: The Plate Reader can now be interchanged with the standard sample holder without need for further alignment.

Operation

Data can be collected from the Plate reader in one of three ways:

- Automatically driving the Plate Reader within a microplate-like matrix coupled with the collection of a wavelength program. This is done using the FL WinLab Well Plate Reader application.
- Automatically driving the Plate Reader in a continuous mode over a flat surface, generating a 3D plot of intensity vs. Distance (mm) vs. Distance (mm). This is done using the FL WinLab TLC Scan application.
- By manually driving the fibre optic to a discrete position followed by running any FL WinLab application (for example Scan). This is done within the FL WinLab Well Plate Reader or TLC Scan applications, depending on the type of sample.

The Well Plate Reader application

The Well Plate Reader application is used to collect data from samples with a discrete format of rows and columns like a microplate.

To drive the Plate Reader to a well, from the **Setup plate** tab click with the right mouse button on a well. The Plate Reader will be driven to this position (in Figure 67, to well B1) and the intensity measured and displayed.

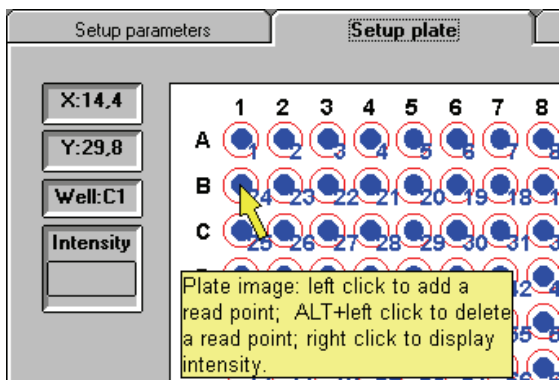

Figure 67 The Well Plate Reader application

NOTE: The Plate Reader will remain at this position until it is sent to a different position, it is sent to Park/Datum position, or a Plate Reader run is started. By opening the Scan application, for example, spectra can be collected from the microplate.

The TLC Scan application

Unlike the Well Plate Reader application, where the accessory is sent to one of a series of discrete positions, the TLC Scan application enables you to send the Plate Reader to any position.

This is done from the **Setup parameters** tab, by moving the mouse over the sample area image until the desired position (shown as X and Y in millimeters on the top left of the tab) and clicking with the right mouse button on the sample area image.

The Plate Reader is sent to the position (in Figure 68, 20 mm from the left side of the plate holder platten, 10 mm from the top edge).

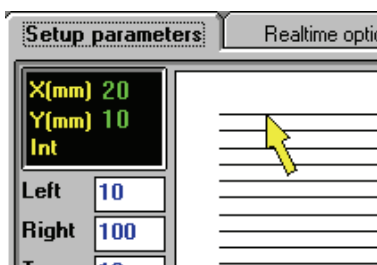

Figure 68 The TLC scan application

Measuring TLC plates, gels or other flat samples

The Plate Reader accessory is shipped with an anodized aluminium plate (L2251251) that is fitted with 2 clips (L2251249) for holding the sample flat to ensure baseline and signal value consistency, as shown in Figure 69.

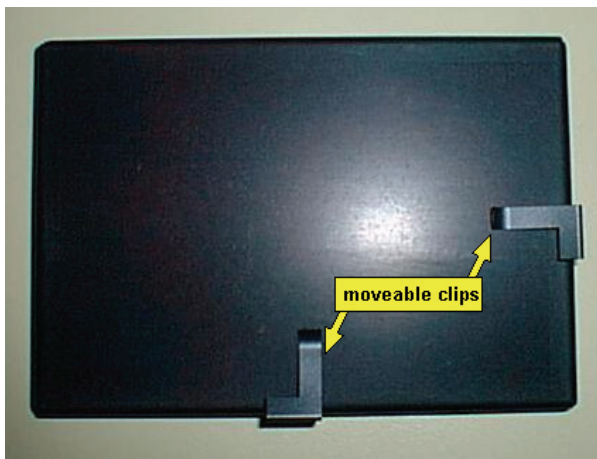

Figure 69 Flat sample holder

This is inserted in place of the microplate in the Plate Reader, the clips are positioned so that they hold the sample securely but do not restrict the movement of the plate reader during measurement.

NOTE: Position the clips so that the fibre optic probe does not come into contact with the clips during movement, or a stepper motor error message will appear, and the run will be aborted.

Red-sensitive Detector



Figure 70 The Red-sensitive detector

Description

The red-sensitive photomultiplier (52124966) is fitted for the collection of emission data above 630 nm, above which point the standard photomultiplier has little or no sensitivity, as shown in Figure 71.

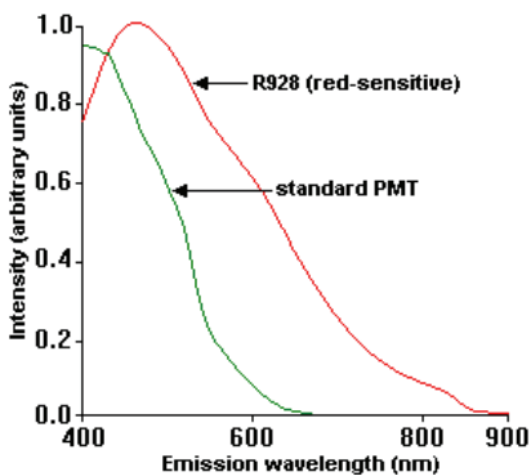

Figure 71 Photomultiplier sensitivity

Installation

The photomultiplier installation procedure must be performed by a PerkinElmer Service Engineer.

NOTE: In order to obtain corrected emission spectra, the correction factor spectrum will have to be collected specifically for the red-sensitive photomultiplier. Data obtained using the standard photomultiplier is not applicable.

Total Emission Accessory

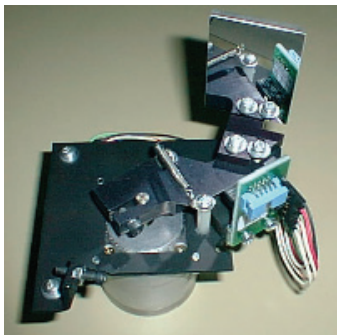

Figure 72 The Total Emission accessory

Description

Gratings used in monochromators have relatively poor transmission of white light. When absolute sensitivity is preferred over spectral resolution, using the zero order position (where the grating transmits white light) gives only small increases in sensitivity. The Total Emission accessory (L2250101) is a mirror which replaces the emission grating in the beam, giving a 10 to 15-fold increase in sensitivity.

Installation

The accessory must be installed in the factory, or by a service engineer, since alignment is required.

CAUTION

Incorrect installation of the accessory can lead to irreparable damage to the emission grating.

Operation

When the Total Emission accessory is fitted, it can be selected in the LS 55 Status application's monochromator dialog. The emission grating is then driven out of the beam and is replaced by the mirror.

Select an emission filter to avoid excitation light being scattered directly onto the sample photomultiplier. If this not done, a warning will be displayed.

NOTE: The use of the Total Emission accessory is strongly recommended for bio- and chemi-luminescence measurements.

External Fibre Optic Accessory

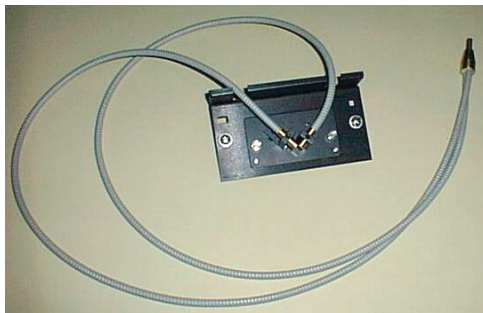

Figure 73 The external fibre optic accessory

Description

The external fibre optic accessory (L2250144) consists of a 1 meter-long fibre optic attached to a sample area holder, and can be used for remote sampling of luminescent samples. The transmission characteristics of silica allow excitation down to approximately 260 nm. At the sampling end, the two fibre bundles are hemispherical, as shown in Figure 74.



Figure 74 The end of the fibre optic accessory

The numerical aperture (around 0.2) of the material produces an emergence/acceptance angle of between 22-25 degrees, as shown in Figure 75.

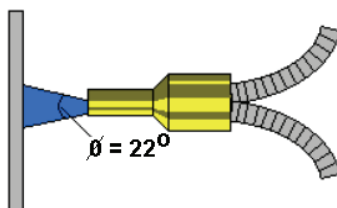

Figure 75 The emergence/acceptance angle

Installation

The accessory needs to be optically aligned to ensure that excitation light passes into the fibre and that emission light from the fibre is correctly passed into the emission monochromator.

Take care not to bend the fibre to a radius of less than 10 cm, as this may cause damage to the fibres.

CAUTION

1. Remove the top cover as described in *Removing the Main Cover* on page 173.
2. Turn off the voltage to the photomultiplier, as shown in Figure 76.

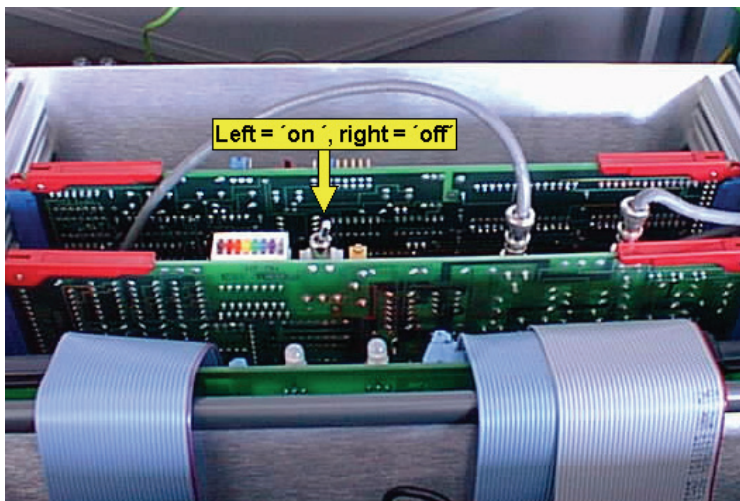

Figure 76 Photomultiplier switch

3. Loosen the two knurled screws underneath the accessory, as shown in Figure 77.

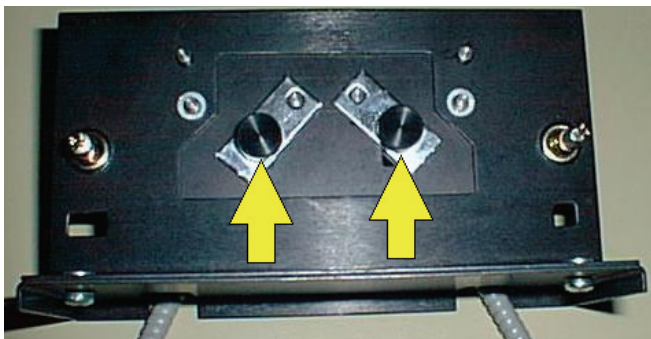

Figure 77 Accessory screws

4. Attach the sample area accessory to the LS 55.
5. Insert the sampling end of the fibre into the right side holder of the sample area accessory and tighten the grub screw, as shown in Figure 78.

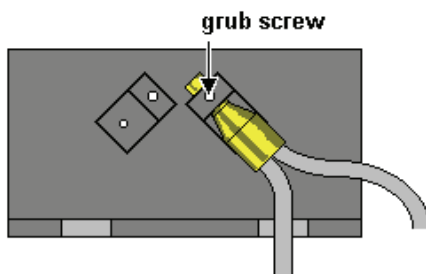

Figure 78 Right holder grub screw

6. Using the FL WinLab LS 55 Status application, set the excitation wavelength to 0 (white light) to give good visibility during alignment.
7. Position the right side holder so that white light enters the fibre and emerges from the two free ends of the fibre optic.
8. Tighten the knurled locking screw underneath the accessory so the right-hand fibre holder is locked in place.
9. Insert one of the free fibre optic ends into the left side holder, as shown in Figure 79.

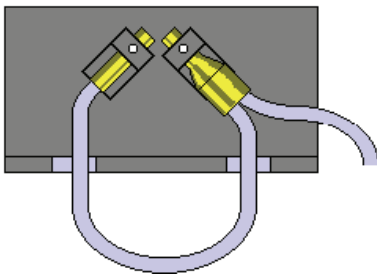

Figure 79 Inserting into the left holder

10. Turn the fibre until it is vertical and tighten the grub screw, as shown in Figure 80.

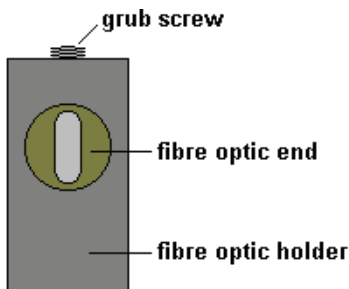

Figure 80 Left holder grub screw

11. Open the central optical cover inside the LS 55 and observe the emission entrance slit through the open position of the emission filter wheel, as shown in Figure 81.

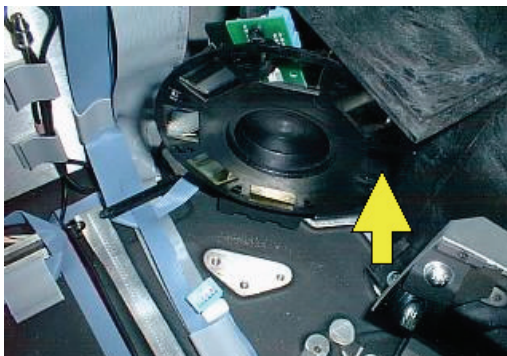

Figure 81 Viewing the emission slit

12. Move the left fibre holder until the light is central on the slit, as shown in Figure 82.

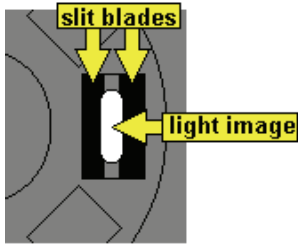

Figure 82 Aligning the light

13. Tighten the knurled screw under the left fibre holder, to lock it.
14. Remove the sampling fibre end from the right fibre holder.
15. Loosen the grub screw in the right fibre holder and insert the free fibre end, as shown in Figure 83.

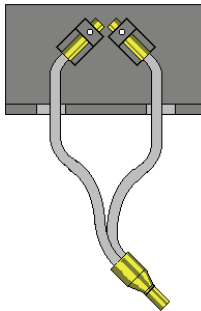

Figure 83 Inserting the fibre end

16. Rotate the fibre until it is vertical then tighten the grub screw (Figure 84).

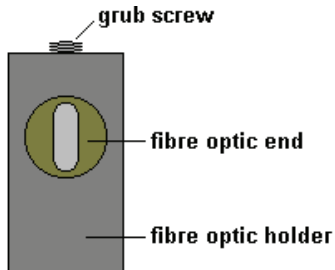

Figure 84 Right holder grub screw

17. Rotate the right fibre until the excitation light beam image is centralized on the optical fibres.
18. Loosen the grub screw again and move the fibre into and out of the holder (keeping the fibre bundle vertical) to optimize the focus.
19. Tighten the knurled screw under the base plate to lock the fibre.
20. Replace the LS 55 central optical cover.
21. Turn on the photomultiplier voltage.
22. Close the main cover.

Operation

The $\sim 22^\circ$ angle of emergence of light from the sampling end means that the further the sampling end is from the sample, the larger the excitation image will be, as shown in Figure 85.

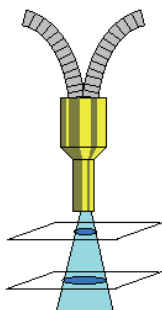

Figure 85 Sampling positions

However, if the sampling end contacts the sample, very little light will be accepted by the emission fibre. Optimal sensitivity is achieved with a 1-2 mm distance between the fibre optic and the sample.

Improving resolution further can be achieved by masking the sampling end of the fibre to eliminate the outer parts of the semicircles from measurement:

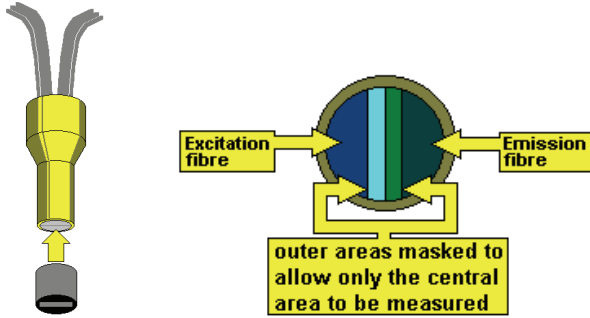

Figure 86 Masking the outer areas

The Fast Filter Accessory

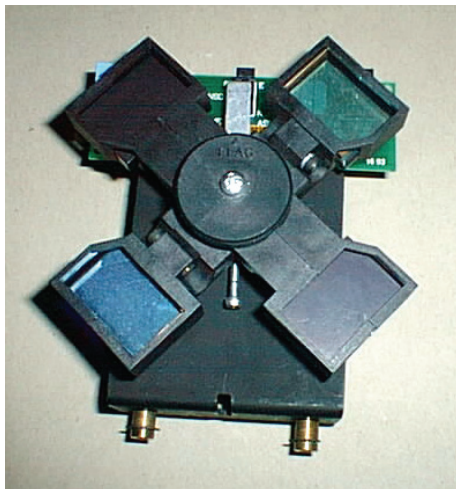

Figure 87 The Fast Filter accessory

Description

The introduction of a range of cell permeable fluorescent probes that bind to intracellular ions, enables cell biologists to study the role of these ions as cellular messengers. Changes in the fluorescent properties of these probes when they chelate to intracellular ions reflect increasing or decreasing concentrations of free ions inside the cell. The spectral properties of some common probes are shown in the table:

Probe	Target ion	Excitation wavelength		Emission wavelength	
		Bound	Free	Bound	Free
FURA-2	Ca ⁺⁺	340 nm	380 nm	510 nm	510 nm
INDO-1	Ca ⁺⁺	355 nm	355 nm	405 nm	480 nm
Mag-FURA-2	Mg ⁺⁺	340 nm	380 nm	510 nm	510 nm
Mag-INDO-1	Mg ⁺⁺	355 nm	355 nm	405 nm	480 nm
BCECF	pH	495 nm	440 nm	530 nm	530 nm
SNARF-1	pH	514 nm	514 nm	580 nm	640 nm

An example of the spectral dependence on ion binding of a fluorescent probe is given by the binding of calcium ions to FURA-2, as shown in Figure 88.

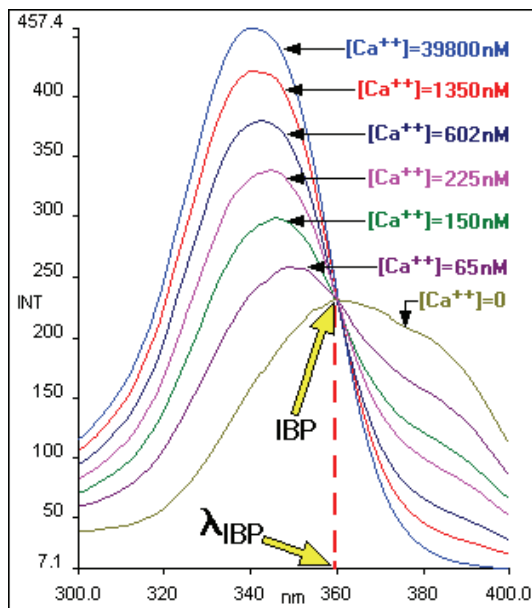

Figure 88 Binding of calcium ions to FURA-2

Installation

The Fast Filter accessory (L2250019) is normally fitted in the factory or is installed by a Service engineer. This involves among other things the installation of the Fast Filter controller circuit board and the base plinths for the Fast Filter drive units. In normal use, the only user access would be to change filters if required. It may be, however, that the user has a set of standard polarizers and one or two Fast Filter wheels. In order to change between Fast Filter operation and standard polarizers, the accessories must be exchanged. It is this process that is described here.

There are two parts to the installation of the Fast Filter accessory, these are the physical installation and the software installation.

Installing filters into the filter wheels

1. Lay the Fast Filter motor unit carefully onto a flat surface.
2. Undo the central screw, as shown in Figure 89.

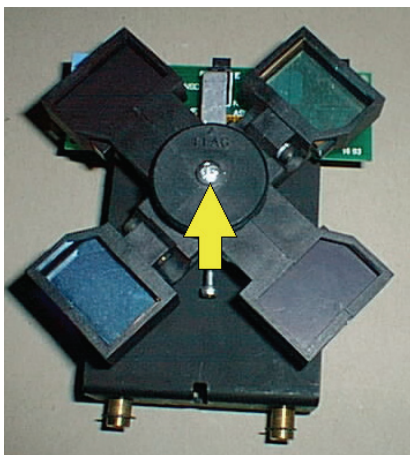

Figure 89 The central screw

3. Remove the 2 filter brackets.
4. Attach the 2 required filter brackets to the Fast Filter motor, as shown in Figure 90.

NOTE: The filter brackets have a peg and slot system on one side and a lapped joint on the other, so they only fit one way round onto the motor assembly.

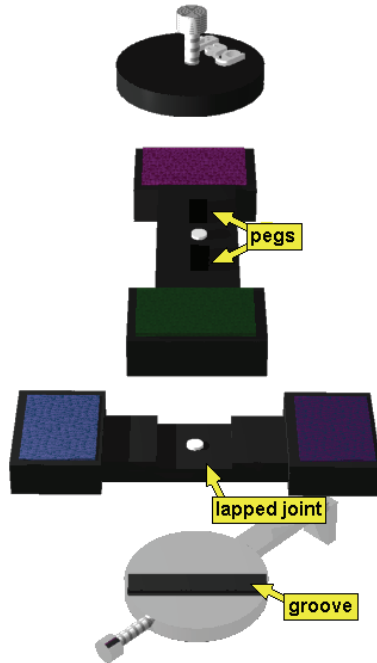

Figure 90 Assembling the filter brackets

The positioning of the filters is predefined:

- For polarizer filters, the vertical filter **MUST** be located in position 1 or 2.
- For ratio filters, the top part of the ratio (for example, the 340 nm filter for FURA-2) **MUST** be located in position 1 or 2.
- The positions for the excitation wheel are shown in Figure 91.

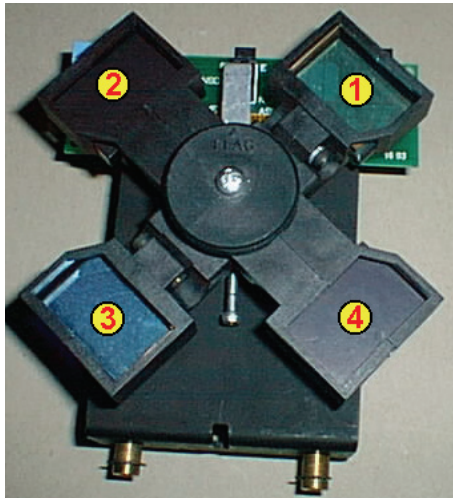

Figure 91 Positions for the excitation wheel

- The positions for the emission wheel are shown in Figure 92.

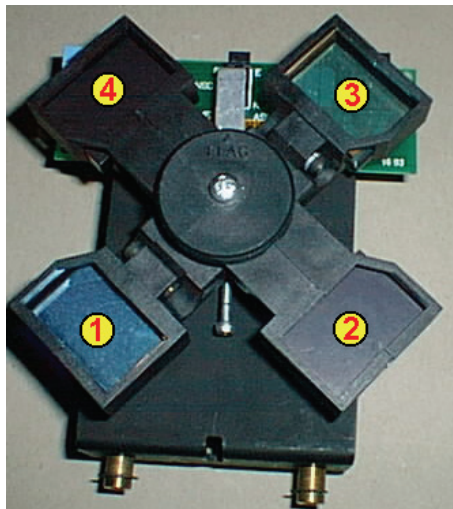

Figure 92 Positions for the emission wheel

Installing the excitation Fast Filter into the LS 55

1. Remove the LS 55 main cover, as described in *Removing the Main Cover* on page 173.

2. Remove the central optical cover as described in *Removing the Main Optical Cover* on page 176.
3. Unplug the excitation filter wheel cable, as shown in Figure 93.

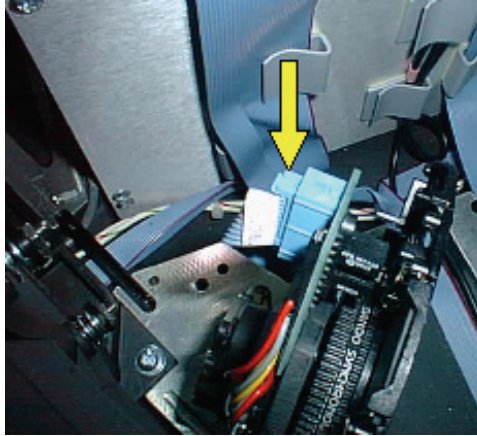

Figure 93 Unplugging the cable

4. Undo the two screws and remove the excitation filter wheel, as shown in Figure 94.

NOTE: Take care not to touch any of the optical surfaces or mirrors.

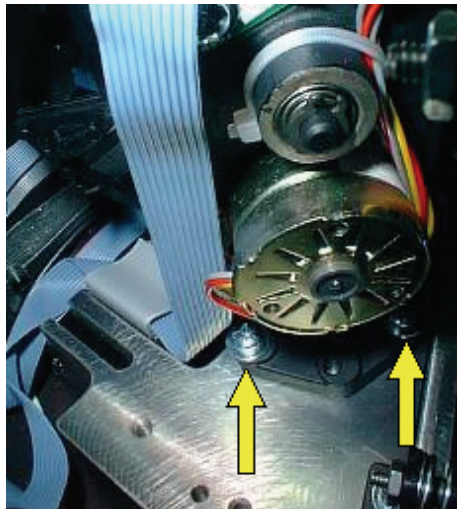

Figure 94 Excitation filter wheel screws

5. Gently pry off the cable clamp to allow access for the Fast Filter plinth.
6. Locate the Fast Filter plinth onto the LS 55 baseplate, first aligning the pin on the baseplate with the hole in the plinth.
7. Secure the plinth using the two long hex screws.
8. Fit the Fast Filter wheel to the plinth, first aligning the pin on the plinth with the hole on the Fast Filter wheel motor assembly.
9. Secure using the 2 long screws fixed to the motor assembly, as shown in Figure 95.

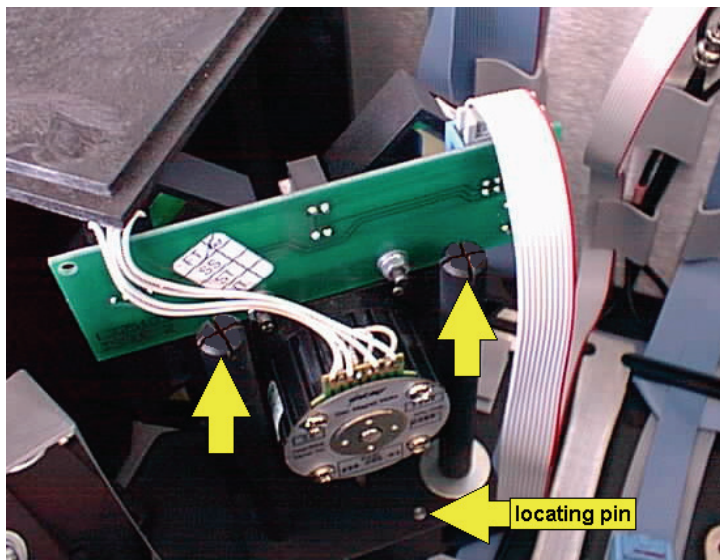

Figure 95 Fixing the filter wheel to the plinth

10. Attach the ribbon cable to the Fast Filter motor assembly.

Installing the emission Fast Filter into the LS 55

The procedure for the emission Fast Filter is the same as the excitation Fast Filter, with the final attaching screws shown in Figure 96.

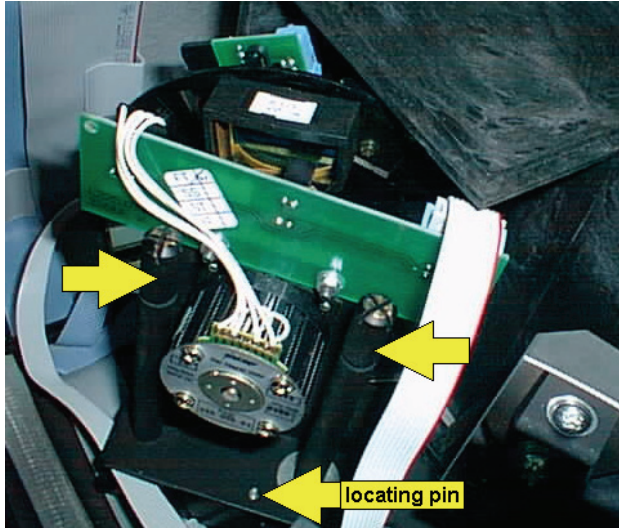

Figure 96 Installing the emission Fast Filter

Cabling and bitswitches

Cables should be arranged as shown in Figure 97.

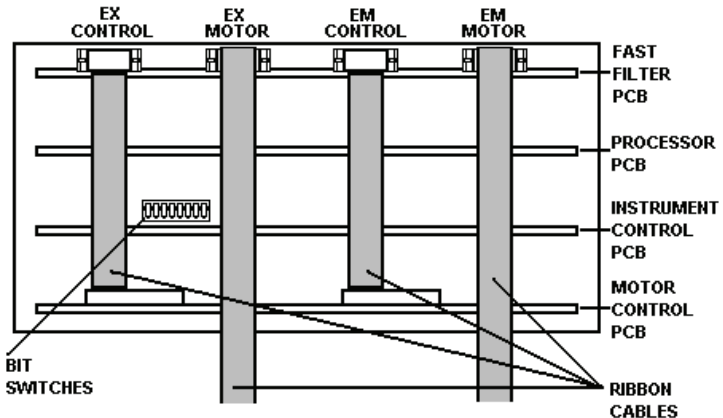

Figure 97 The cabling

Bit switches on the instrument control VME board should be setup depending on whether an Excitation Fast Filter, an Emission Fast Filter or both were fitted as follows:

NOTE: Only the first two bit switches should be moved, the other switches are shown here for example purposes, but must not be moved from their factory settings.

- Both -



- Emission only -



- Excitation only -



Software installation

After physical installation of the Fast Filter wheels, the FL WinLab software must be configured so that it knows where the filters are.

1. Choose **Configuration** from the Utilities menu.

The Configuration dialog is displayed.

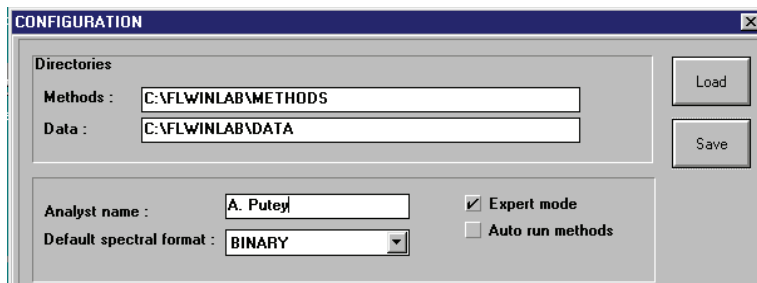

2. Ensure that **Expert mode** is selected, and then click **OK**.

3. Select **LS 55 Status** from the Application menu.

The LS 55 Status dialog is displayed.

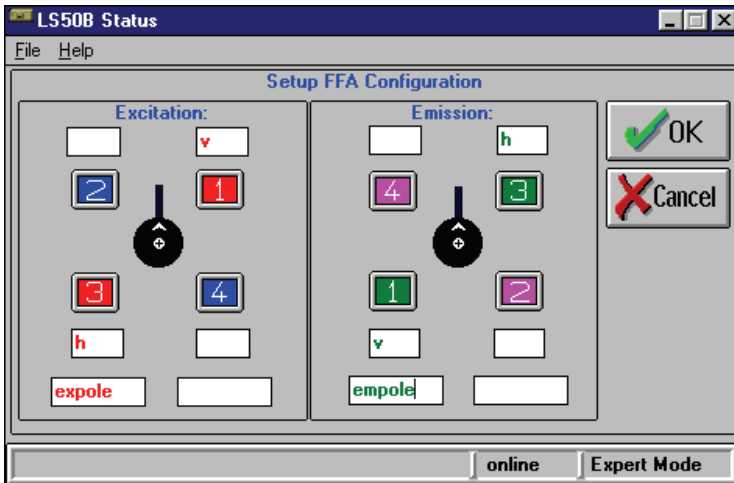

4. Enter the positions of the filters in the dialog.

For example: for polarizers, the entries would be made similar to those shown above (note that the vertical polariser must be in position 1 or 2), while for ratio measurement filters, the entries would be similar to those shown below (note here that the top (numerator) part of the filter pair must be in position 1 or 2 as shown).

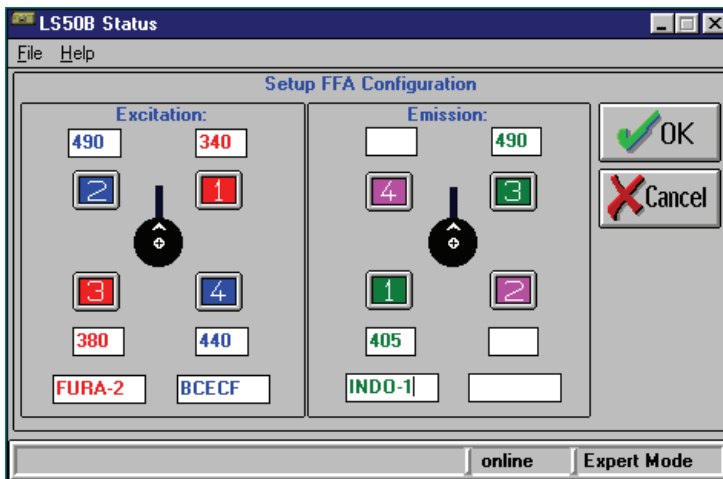

5. When the positions of the filters have been entered, click **OK**.

The settings will then be saved.

Operation

Collection of data using the Fast Filter accessory is performed using the Fast Filter application in the FL WinLab menu.

On starting, the Fast Filter application interrogates the filter position information entered via the LS 55 Status application. If polarizers are present then options for time-dependent collection of polarization and anisotropy will be offered. If the filters are standard band-pass type, then ratiometric options are offered.

A description of the Fast Filter application is given in the FL WinLab Software manual.

The Polarizer Accessory

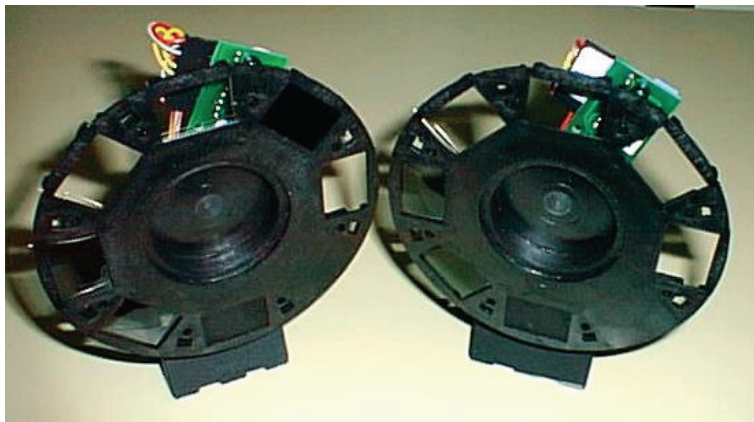

Figure 98 The Polarizer accessory

Description

The polarizer accessory (L2250100) consists of two filter wheels fitted with polarizing elements. The polarizers are fitted inside the optical system of the LS 55 and are driven automatically. When the polarizers are not in use they are driven out of the beam restoring the full functionality of the LS 55.

Typical applications include the investigation of membrane structure, protein structure and function and polarization immunoassays.

NOTE: The use of plastic cuvettes will give severe corruption of polarization and anisotropy measurements, since the plastic material strongly polarizes light. Glass (or better, synthetic fused silica) cuvettes should be used.

When using the polarizer, the temperature of the sample should also be controlled by connecting a water bath to the thermostatable cellholder, since both are temperature-dependent. Also, the stirrer should be activated to provide a homogeneous temperature throughout the cuvette.

Installation

The polarizers are normally factory fitted or service installed. However, if you need to change between Fast Filter wheels and polarizers, follow this procedure:

1. Remove the LS 55 main cover, as described in *Removing the Main Cover* on page 173.
2. Remove the central optical cover as described in *Removing the Main Optical Cover* on page 176.
3. Unplug the excitation filter wheel cable, as shown in Figure 99.

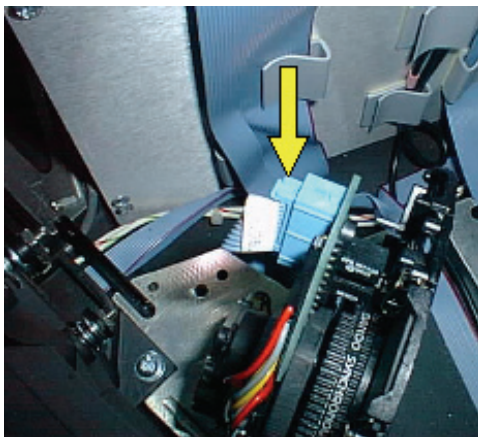

Figure 99 Excitation filter wheel cable

4. Undo the two screws and remove the excitation filter wheel, as shown in Figure 100.

NOTE: Take care not to touch any of the optical surfaces or mirrors.

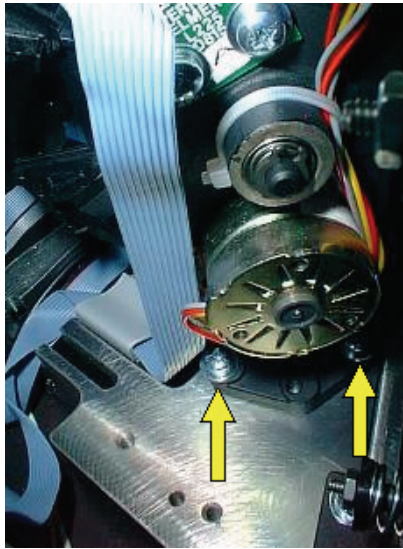

Figure 100 Excitation wheel screws

5. Fix the excitation polarizer wheel into the excitation filter wheel location by first locating the hole on the bottom of the filter bracket with the pin in the baseplate, then by tightening the two fixing screws, as shown in Figure 101.

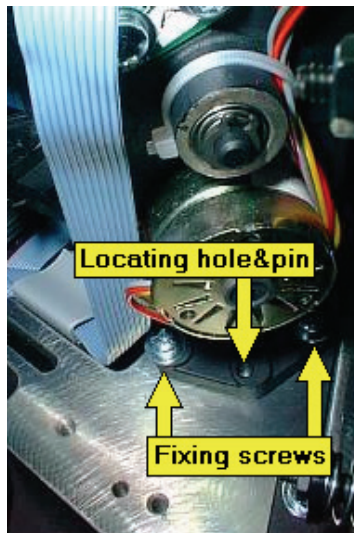

Figure 101 Fixing the excitation polarizer wheel in position

6. Attach the excitation filter wheel control cable, as shown in Figure 102.

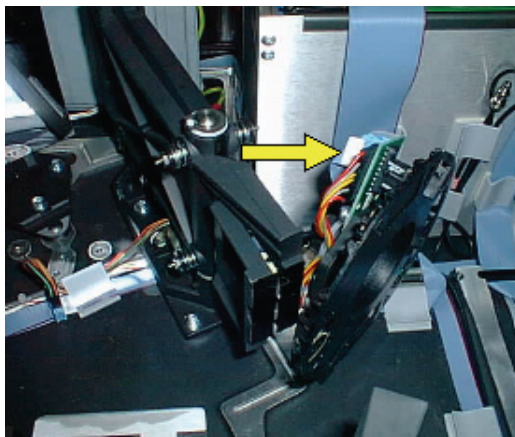

Figure 102 Attaching the excitation control cable

7. Fix the emission polarizer into the emission filter wheel location, using the locating hole and pin for initial location of the wheel, as shown in Figure 103.

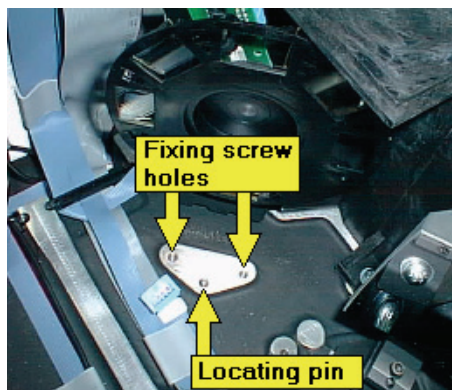

Figure 103 Fixing the emission polarizer wheel in position

8. Before tightening the fixing screws fully, check that the emission filter wheel and emission polarizer wheel are correctly set and do not touch one another during rotation, as shown in Figure 104.

Do this by manually rotating the two wheels in opposite directions. If the wheels touch, gently turn the polarizer wheel until the two wheels do not meet.

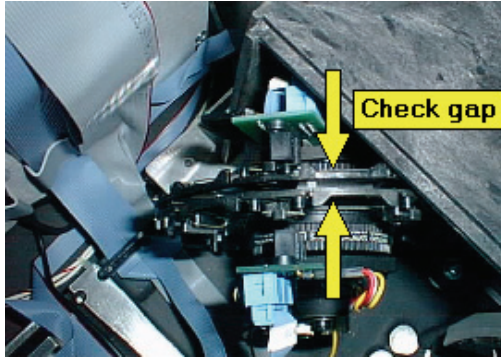

Figure 104 Checking the clearance

9. Tighten the polariser wheel fixing screws.
10. Attach the emission filter wheel control cable, as shown in Figure 105.

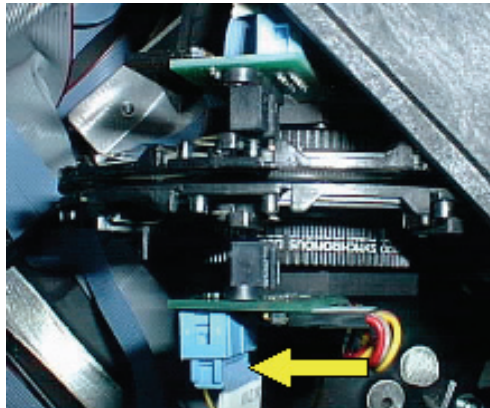

Figure 105 Attaching the emission control cable

11. Refit the LS 55 covers.

Bit Switches

When the Polarizer accessory has been fitted, the first two bit switches (shown in black) on the instrument control VME board must be set to off (as shown in Figure 106).

NOTE: The other bit switches (shown in gray) are shown as an example, but must not be changed from their original factory settings.

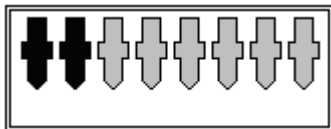

Figure 106 Bit switch settings for the Polarizer accessory

Operation

The measurement of polarization or anisotropy values can be performed using the FL WinLab software, where movement of the polarizers is done completely automatically.

1. In the FL WinLab software, select **Read** from the Applications menu.
2. Choose **polarization** or **anisotropy**.

The polarisation/anisotropy value will be saved together with instrument parameters in the file specified in the **Destination filename** textbox. The format of the data file is as follows:

```

Mode:      Polarisation      Date:      16.07.98 09:57:34
Time Cuv  ExSlit  EmSlit  ExWave  EmWave  Int  Temp  Ivv  Ivh  GF  P  Comment
0.0  1   10   10   350  455   1  30.0  123.5  97.6  0.93  0.153  DPH in DMPL 1:500 [surfactant]=1.3mM
      1   10   10   350  455   1  30.0  123.5  85.2  0.93  0.218  DPH in DMPL 1:500 [surfactant]=0.65mM
    
```

The Low Temperature Accessory

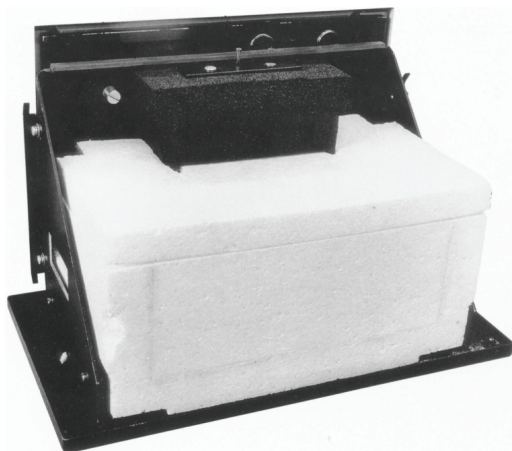

Figure 107 Low Temperature Accessory (without cover)



WARNING

This accessory uses liquid nitrogen to cool the sample to 77 K. During filling of the liquid nitrogen tank, protective gloves must be worn and care must be taken not to touch the metal surfaces of the accessory with unprotected hands.

Description

The Low Temperature Accessory can be used for measurement of fluorescence and phosphorescence from liquid samples at liquid nitrogen temperature (77 K).

The sample is located in a silica capillary tube of 4 mm outer diameter, 2 mm inner diameter and 75 mm length. This tube is held in contact with the top of a high purity copper rod, the bottom end of which is immersed in liquid nitrogen.

The advantages of this system over traditional Dewar flasks are:

- Bubbles do not occur within the optical path since the nitrogen tank is located below the optical plane of the instrument, leading to reduced noise.
- Positioning of the cuvette and hence signal reproducibility are more accurate.
- Cooling occurs more rapidly, allowing for improved sample throughput.
- Fewer reflective and absorptive surfaces are located within the optical path.

Installation

Before installing the accessory, any filters or attenuators that need to be inserted into the sample area brackets should be installed. Figure 108 shows the parts of the Low Temperature Accessory.

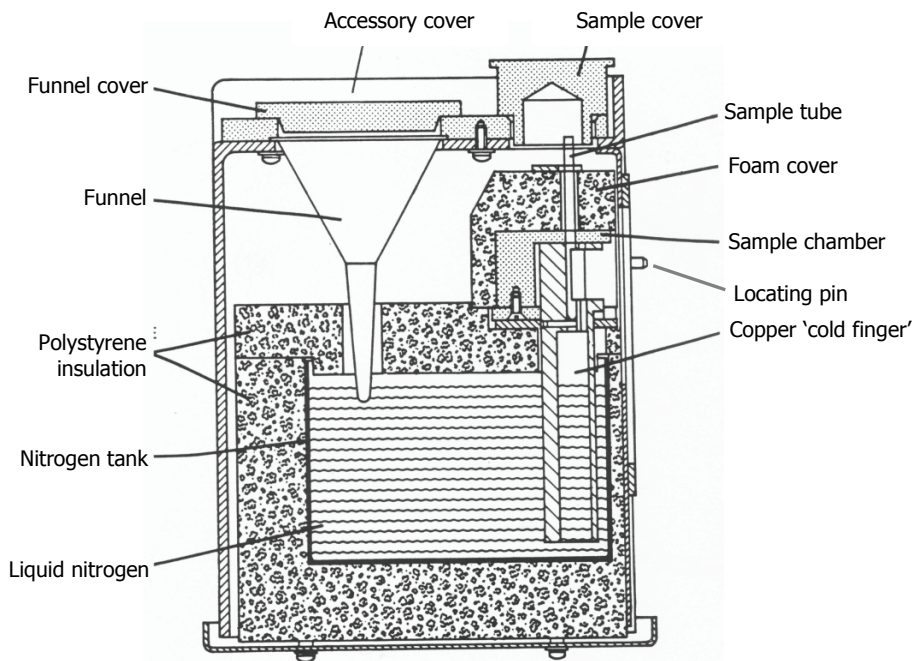

Figure 108 Cross-section through the Low Temperature Accessory

1. Switch off the instrument and remove the mains supply cable.
2. Open the sample area cover and remove the current sample accessory.
3. Remove the sample area cover and accessory bracket by undoing the three fixing screws as shown in Figure 109.

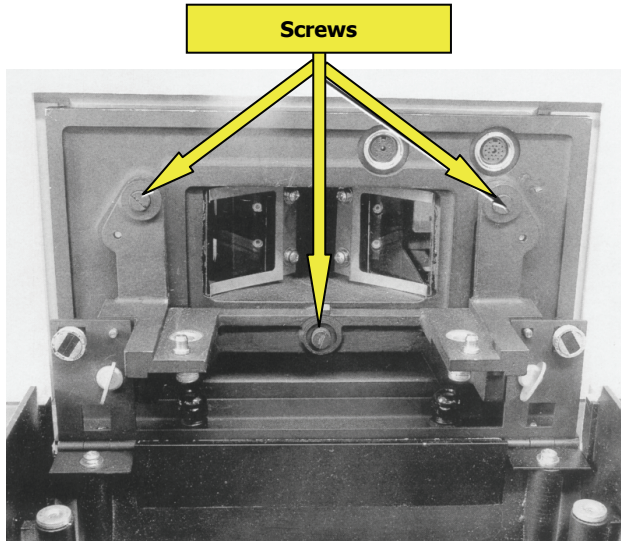

Figure 109 Accessory bracket screws

4. Place the accessory on a stable surface and remove the shipping tape.
5. Lift the cover vertically from the accessory.
The black foam block around the sample tube holder will now be visible.

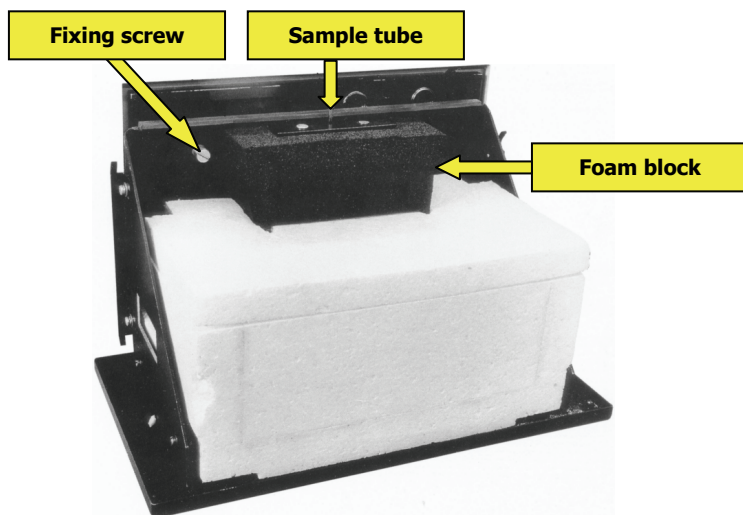

Figure 110 Low Temperature Accessory with cover removed

6. Insert the two locating pins (see Figure 108) into the corresponding holes on the instrument accessory plate.
7. Secure the two accessory fixing screws at the top of the accessory (as shown in Figure 110, the right-hand screw is hidden by the black foam block) and the two screws at the bottom of the accessory.
8. Insert the mains supply cable and switch on the instrument.

Alignment

Before samples can be measured with the Low Temperature Accessory, you must align the sample tube position to centralize it in the focus point where the excitation and emission beams cross. This must be performed at room temperature.

1. Remove the two screws that secure the black foam block, and remove the foam block and the black metal securing plate.
2. Loosen (but do not remove) the four screws that secure the sample holder block.
3. Prepare a solution of a suitable fluorescent sample.
For example 0.2mg/ml coronene in cyclohexane.
4. Fill one of the sample tubes to a depth of 30mm with the sample.

5. Wipe the outside of the tube to dry it, and then insert the tube gently down through the opening in the sample holder block.
6. In FI WinLab, start the TimeDrive application and enter the following parameters:
 - Duration: 10 minutes
 - Data interval: 0.1 second
 - Excitation wavelength 302nm
 - Emission wavelength 445nm
 - Slits 5nm/5nm Ex/Em

NOTE: These parameters are only for using coronene as the sample. If another sample is used, then the excitation and emission wavelengths will have to be set accordingly.

7. Start the TimeDrive by clicking the Green traffic light.
8. Locate the tube center in the focus crossover point to find the highest intensity.

It is useful to look down into the sample tube. The fluorescence emission is in the visible region, allowing you to see when the sample is being excited optimally.

NOTE: There are two positions that produce high signals. The first is that which correctly locates the center of the sample tube in the crossover point of the excitation and emission light beams. This is the desired position. The second position is that which causes light to be reflected directly from the outer surface of the sample tube. This signal is unfortunately often higher than the fluorescence signal. Determine that the position achieved after alignment is correct by exchanging the sample tube for one containing only solvent. If the signal changes dramatically, then the position is optimized for fluorescence. If the signal does not change significantly, then the position is optimized for scattered light, requiring further alignment.

9. Tighten the four securing screws.

During this, the position of the sample tube may shift slightly. Confirm that the signal is as high as the maximum seen during alignment. If not, repeat the alignment process above.

10. Remove the sample tube from the sample holder block and replace the black foam block.
11. Place the black metal securing strip on top of the foam block, and secure it using the two screws removed previously.
12. Replace the top cover of the accessory.

Purging the instrument

Before measurement at liquid nitrogen temperatures can be performed, the instrument must be purged with dry gas, for example helium or nitrogen. This gas must be free of carbon dioxide and moisture.

The purpose of purging is to avoid the build-up of ice on optical surfaces inside the instrument, in the sample area and on the sample tube itself. A gas flow rate of 0.5 L/min is normally sufficient.

The gas flow must be connected to the purge nozzle under the instrument as shown in Figure 111.

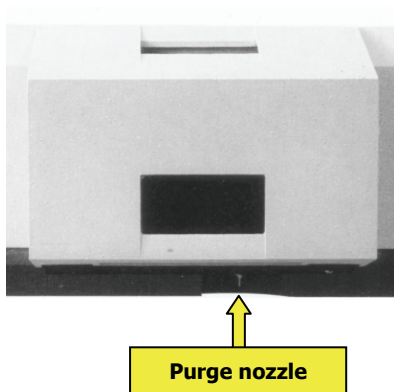

Figure 111 Location of the purge nozzle

Filling the accessory with liquid nitrogen



WARNING

During filling of the liquid nitrogen tank, protective gloves must be worn and care must be taken not to touch the metal surfaces of the accessory with unprotected hands.

NOTE: During filling, an empty sample tube should be located in the accessory to avoid icing in the sample holder position.

1. Remove the sample cover and gently push an empty sample tube vertically into the hole in the black cover plate.
Some resistance will be encountered when the tube comes into contact with the two clips which secure the tube, turn the tube if necessary to overcome this resistance.
2. Remove the funnel cover and carefully pour liquid nitrogen into the funnel. This will require approximately 3 L of liquid nitrogen.
Pour slowly until the tank overflows. When the copper finger has almost reached temperature, the liquid nitrogen will boil for several seconds, after this the system settles down.
3. When the boiling has subsided, the tank should be slowly filled to overflowing.
4. Close the funnel cover, remove the sample tube and replace the sample cover.

NOTE: To maintain constant temperature, approximately 1 L of liquid nitrogen will be required for each hour of use (depending on room temperature). The accessory should be topped up with liquid nitrogen every 10 to 15 minutes to ensure temperature stability.

Operation

1. Prepare a solution of the sample for measurement.

Suitable solvents are ethanol, cyclohexane or methylcyclohexane or a mixture of diethylether, isopentane and ethanol (EPA) in the ratio 5:5:2.

Do not use water as solvent, the pressure caused by freezing will burst the capillary.

CAUTION

2. Using a narrow pipette, fill a clean, dry sample tube to a depth of at least 30 mm (equivalent to approximately 100 μ L of sample).
Ensure that the sample is free of bubbles.
3. Wipe the outer surface of the tube dry.
4. Remove the empty tube from the sample holder and replace with the sample tube, replace the sample cover.
The sample cover should be open for as short a time as possible to avoid condensation build-up in the sample holder area.
5. Observe the sample cooling by monitoring sample signal against time, preferably with the FI WinLab TimeDrive application.
The sample should require about 1 minute to reach 77 K.
6. Measure the sample fluorescence or phosphorescence as desired.
If the measurement takes more than ten minutes, the sample tube should be rotated through 360 degrees to avoid liquid carbon dioxide building up in the sample holder area.

NOTE: A potential problem is snowing of the solvent. In this case, the solvent does not freeze to a clear glass, but shows white flecks. This can be determined by rapidly removing the tube and observing it. If snowing occurs, this does not prohibit qualitative and quantitative analyses, but gives much higher background levels and lowered sensitivity. The snowing effect may be removed by changing the solvent. Methylcyclohexane, for example, forms a clear glass, while hexane forms a snow.

NOTE: The circular cross-section of the sample tube can cause stray light to be reflected into the emission light path. Select one of the emission cut-off filters (see the FL WinLab Software User's Guide) to remove second- and third order stray light from spectra.

7. When the accessory returns to room temperature after use, it can accumulate condensation from water. If the accessory is to be used again within several hours, ensure that the copper finger is dry by wiping with a paper tissue.

NOTE: Whilst the accessory is at liquid nitrogen temperature, the sample position should never be empty: insert an empty tube into the sample holder to avoid this if necessary. The empty sample position can accumulate CO₂ ice, making it impossible to insert a sample. This could require allowing the accessory to return to room temperature and repeating the cooling-down process.

Removing the accessory



WARNING

Always allow the accessory to return to room temperature before removal and handling.

1. Turn off the purge supply to conserve gas.
2. Remove the outer cover of the accessory by lifting it vertically upward.
3. Undo the four screws securing the accessory and store the accessory in a safe place.
4. Secure the standard cellholder area to the instrument.

Accessory spares

The following spares are available:

Accessory	Description	Part Number
Stirred cellchanger	Stirrer bars (pack/6)	04978499
Thermostatable cellholders	Tubing (2m)	04973213
Front Surface	Powder holder complete with silica window	52123164
Front Surface	Silica window for powder holder	52123814
Septum injector	Silicone rubber septa (pack)	
Any cuvette holder	Semi-micro cuvette adapter	
1cm Square-top cuvettes	Coverslip accessory	
	Pulsed xenon source	L2251157
	Red-sensitive photomultiplier	52124966
	Festoon (filament) lamp	04969486
Plate reader	Hi-white 96-well microplates (pack of 100)	L2251692

RS232 Commands

Introduction

This section describes the instrument resident software in the Model LS 55 Luminescence Spectrometer.

All the instrument facilities described in this section are controlled via a single RS232C communications channel at 9600 baud. Data is output via the RS232C link and is also output in analogue form. The instrument has the following facilities:

- The SCAN BUSY logic output is asserted when the instrument is collecting data for output via the RS232 channel.
- Two general-purpose logic inputs are provided. One (EVENT) is used to mark output data with timed events; the other (START) is used by external devices to prompt data collection.

NOTE: In older instruments, the EVENT output is labeled 'Remote Start' and the START input is labeled 'Remote Integrate'.

- Both monochromators may be driven to any valid wavelength (200-800 nm for excitation and 200-900 nm for emission). They may be scanned either individually or synchronously. When synchronously scanning either a constant wavelength separation or a constant frequency separation can be selected. All these operations can be aborted.
- The source is automatically turned off 30 minutes after the last external control command is received if data collection is not active.
- Data collection may be set up to operate in fluorescence, phosphorescence or bio-/chemi-luminescence modes. Data may be collected while the monochromators are stationary or scanning. In phosphorescence, bio or chemi-luminescence modes the main emission gate and delay times are fully adjustable in steps of 10 microseconds. Control is also available over the number of flashes and length of a data collection cycle. In bioluminescence mode the source is turned off and ratioing disabled.

- Collected data is excitation corrected, block averaged, ratioed, normalized, and smoothed. Excitation correction is achieved by reference to a table of correction factors held in non-volatile memory. Smoothing filters are 'Savitsky-Golay' or binomial types with filter widths user selectable as any odd number between 3 and 101 points. Normalization is by linear interpolation between nearest points to return data at specified abscissa interval.
- Data output is via RS232 and analogue output. Data may be output from anywhere on the data processing chain with the restriction that only one data value per mains cycle may be Output. Data to the analogue output may be scaled.
- Facilities are included to generate the excitation correction tables.
- Both slits are independently driveable. Automatic facilities are available for calibration. Calibration data is held in non-volatile memory. Preset photomultiplier (PMT) voltages are set up as a function of excitation slit setting.
- The emission filter wheel may be driven to any position independent of other instrument conditions. The excitation filter is selected automatically according to the current excitation monochromator position, unless a polarizer or blank position has been selected. A manual override to the automatic excitation filter selection is provided. A separate emission polarizer wheel accessory is provided.
- If fitted, a total emission accessory (emission mirror) can be driven in or out of the beam.
- A timed-event marker accessory fitted with temperature sensor and stirrer is supported.
- An x-y table may be used as a well plate multisampler or as a TLC plate reader. When used as a TLC plate reader, the probe may be scanned at constant speed parallel to a selected axis.
- A magnetic stirrer is available as an accessory and may be set to one of two possible speeds.
- A peristaltic pump is supported. It may be driven in either direction for a specified period of time.
- A motor driven, four position cell holder is supported.

NOTE: The accessories fitted internally to the instrument (for example, polariser wheels, emission mirror) are detected on power on and upon a warm start. If an accessory is removed while the power is on, the software will recognize this but will not recognize a refitted accessory until after a power on or warm start.

Accessories fitted externally (plug-in accessories) are detected dynamically; the software responds immediately to accessories being plugged in or removed. For more complex plug-in accessories (for example the autosampling accessory), some initialization in addition to plugging in may be required before the software can control the device correctly. The software will respond to control commands for an incorrectly initialized accessory as if the accessory was not fitted.

Section 1- RS232C Communications

All facilities are controllable via the RS232C link. Data transmission is fixed at 9600 baud, 8 bits, no parity and 1 stop bit. The instrument is always ready to receive data. All data sent from the instrument is in response to a command sent to it. The instrument outputs a busy error code if it is executing a command and another command is received. An exception to this rule occurs when interpreting an abortable command and the command received is abort. In such cases an error code is not output in response to the abort command - the error code sent in response to the original command will indicate that the command was aborted. The second exception is when a calibration command is active and a continue command is expected.

The RS232C interface may operate in either free-running or prompted modes. In free-running mode output can be stopped/restarted by conventional DC1/DC3 protocol. DC3 pauses transmission at the end of the current record being transmitted. The interface, defaults to prompted mode on power up.

The 25-way connector on the instrument is configured as DCE:

pin 1	chassis ground	pin 6	DSR
pin 2	data from instrument	pin 7	signal ground
pin 3	data to instrument	pin 8	RCD
pin 4	RTS	pin 20	DTR
pin 5	CTS		

No connections are made to the other pins.

Data sent to the instrument is either a command or special character.

Command syntax is as follows:

$$\$ \langle \text{mnemonic} \rangle \langle \text{parameter list} \rangle \langle \text{terminator} \rangle$$

Where:

- The mnemonic is always 2 alpha characters. (Refer to *Section 2 - Command Formats* on page 131 for valid mnemonics.)
- The parameter list is a series of parameters delimited by a comma (,). A parameter is a series of ASCII characters representing integer, real, or string.
- The terminator is a single character: either c/r or l/f.

A command string, including the terminator, may not be longer than 128 characters.

Special characters are as follows:

- BS or % characters may be used to delete the previous character in a command string.
- NULL and DEL are ignored.
- DC1 prompts output when in prompted mode or causes return to free-running mode in the case that prompted mode was entered by receipt of DC3. Up to 32767 prompts may be accumulated. DC1 is ignored in free running mode.
- DC3 causes entry to prompted mode if in free-running mode, otherwise it is ignored.

Data is output in the form of records of up to 126 ASCII characters terminated with c/r and l/f or as a fixed length record of 40 bytes in the case of binary data transmission. The first response to any command is an output record consisting of a 4 digit error code. On some commands other output records may follow. The last transmission in response to a command is an error code output record. Any output records that do not contain only an error code have a DEL character in the first position.

In some cases the user may start an operation which requires some interaction with the user (for example, calibration procedures). In such cases unique error codes may be returned indicating to the user that either text or spectral data records are to follow. Another unique code indicates that no more data will be sent in response to this command but that the operation started is still active and is awaiting instruction in the form of one of the dialogue commands (for example, Continue). Only when the operation has finished will one of the normal error codes be sent indicating success or failure of the whole operation.

Monochromator Drive

The monochromators may be driven in one of two modes:

In Scan mode, either or both monochromators may be driven between specified limits. If both monochromators are driven, the excitation monochromator is driven at the specified constant wavelength speed and the emission monochromator either a constant wavelength or constant frequency offset from the excitation monochromator. If a single monochromator is driven, then it is at the specified wavelength speed.

The Scan start is synchronized to a mains cycle. Velocity may be 10 to 1500 nm/min or -10 to -1500 nm/min. Limits are specified for each monochromator and must be in the range 200 to 800 nm for excitation, and 200 to 900 nm for emission. Wavelengths are a multiple of 0.1 nm. Scanning is in the direction specified by the sign of the scan velocity. A scan ends when one of the monochromators encounters its end limit or on an abort request.

In GOTO mode either monochromator is driven as fast as possible in the specified direction. Destination wavelengths must either be 0 nm or within the scan limits above. Unless an excitation polariser or blank position has been selected or a fast filter excitation unit is fitted, the excitation filter is selected according to the excitation monochromator destination. For excitation wavelengths <410 nm, a clear (no filter) position is selected, otherwise a 350 nm cutoff filter is used. A GOTO ends when the monochromator and excitation filter is at its destination, or when abort is requested.

Plate Reader Driver

The plate reader may be used as a well plate reader or as a TLC plate reader. In TLC plate reader mode the motors may be moved either in Scan or GOTO modes but in well plate mode only GOTO mode is available.

Positions are specified in units of 0.1 nm in the TLC plate reader case and as sample positions (1-96) in the well plate case.

In Scan mode the limits are 0 to 99.0 mm for the x-axis and 0 to 63.0 mm for the y-axis. The scan is in the direction specified by the sign of the speed.

Source Control and Photomultiplier Control

Thirty minutes after the last user command has been completed, the source is turned off but the idle time drive continues.

The PMT voltage is set nominally to a voltage dependent on the excitation slit position and the position of the excitation monochromator.

A PMT overload detection mechanism operates to indicate conditions where the ordinate data may be distorted by saturation effects. An error is indicated if the protection mechanism becomes active during a period of data collection but data collection continues.

Slit and Filter Motors

All motors listed here may only be driven when a scan or time drive is not active.

Excitation and emission slits are provided as standard and each may be independently driven in the range 0 and 2.5 to 15 nm (excitation), 0 and 2.5 to 20 nm (emission) to positions that are multiples of 0.1 nm.

NOTE: Slit settings below 2.5 nm are not calibrated.

An emission mirror is provided as an option. When the mirror is moved into place the emission monochromator is driven to 800 nm and emission wavelength subsequently assumed to be 0.

An emission filter with 8 positions is provided. The positions are: cut-off filter 1 to 5; blank; 1% attenuator and no filter.

An excitation cutoff filter at 390 nm is provided. This is switched in to the beam at 410 nm to remove second order artifacts.

An emission polarizer is provided as an accessory with the following positions: horizontal polarizing filter; vertical polarizing filter; and no filter.

An excitation polarizer is provided as an accessory with the following positions: horizontal polarizing filter, vertical polarizing filter, blank, and no filter.

A conceptual excitation shutter is provided in the form of an independent source ON/OFF switch.

Analogue Output

Analogue outputs of 0 - 10 V and 0 - 1 V are provided with a resolution of one part in 1024. The data output is processed in the same way as that output via the RS232C channel. The data is multiplied by a user specified scaling factor and then a user specified offset is added before output.

Sample Acquisition Accessories

There are 4 types of sample acquisition accessory available: the peristaltic pump, the four-position cellchanger, the plate reader and the biokinetic accessory.

- The peristaltic pump may be driven in either direction for a period of time specified in units of 0.1 seconds. Pumping may be aborted at any time by the user.
- The four-position cellchanger may be driven to position. The cellchanger may be fitted with coils driving magnetic stirrer bars. The stirrer speed may be set to one of three values: off; low; high.
- The plate reader can be used to read samples from a well plate, a TLC plate or a gel. For a well plate, the plate reader takes a reading at each well. For a TLC plate or gel, the plate is scanned in the x or y direction, starting at specified co-ordinates.
- The biokinetic accessory enables the temperature of the cell to be measured. It also has a stirrer as in the four-position cell holder (above) and the facility for event marking.

The Sipper, cell holder, and plate reader accessories require initialization before they are used. Initialization is required each time they are plugged into the instrument or if any operation is performed that changes the motor position(s) other than under control of the instrument. Explicit initialization commands are available. The instrument software automatically initializes accessories if a command to move a fitted accessory is issued and the accessory has not been initialized since it was last plugged in. An error is reported from accessory control commands if the accessory becomes unplugged at any time before or during the command or if the software initialization is unsuccessful.

Fast Filter Accessory (FFA)

Fast rotating filter units for excitation and emission can be fitted in place of the excitation filter/polarizer wheel and emission polarizer wheel. The FFA units are synchronized with the source flash and fluorescence data collection cycle. Data points are collected and output for each filter position at a rate controlled by the \$FI command. The maximum data output rate is one point or filter position per fluorescence data collection cycle (mains cycle). Data collection is not possible in modes other than fluorescence.

The FFA units are controlled by a separate microprocessor board fitted with the existing VME boards. When FFA units are signaled fitted by the bit switch settings detailed on page 102, control signals are passed between the CPU and FFA control board via the ports usually used for the excitation filter/polarizer wheel and emission polarizer wheel accessory. If the bit switches are not set correctly inappropriate signals will be sent by the CPU and the accessories will not function.

During FFA data collection, synchronization pulses from the FFA board are monitored by the CPU software. Pulses must occur exactly once per filter unit rotation, be at least 1.7 ms in duration, and start in a window between 7.0 and 11.0 ms after the source flash (50 Hz and 60 Hz operation). If these conditions are not observed, data collection is terminated immediately and an error reported via the RS232C data output.

Section 2 - Command Formats

Following is a list of error codes.

0000 No error.

CODES INDICATING END OF COMMAND EXECUTION

- 0002 Command not recognized.
- 0003 Invalid parameter format (real where integer expected).
- 0005 Not enough parameters.
- 0006 Illegal character in expected numeric parameter.
- 0008 Negative numeric where positive expected.
- 0009 Value out of range.
- 0014 Input buffer overflow.
- 0022 Parity, framing, or overrun error.
- 0099 Abort termination of command.
- 0100 Accessory not fitted.
- 0103 Invalid phosphorescence data collection parameters.
- 0104 Calibration peak not found.
- 0105 Calibration operation not successful - user message gives reason.
- 0106 Non-volatile memory error - fatal.
- 0107 PMT over range warning.
- 0108 Non-volatile memory error - recovered from backup copies.
- 0109 Too many parameters.
- 0110 Instrument busy.
- 0111 Invalid parameter for instrument in current state.
- 0112 Motor stepping error or Fast Filter Accessory missing synchronous pulse.

- 0113 Scan finished prematurely but not due to abort command (for example excess speed in constant frequency scan).
- 0114 Scan recoverable error (data integrity cannot be guaranteed).
- 0200 to 0215 Auto-calibration operation internal errors. (User text messages give details).

CODES NOT INDICATING END OF COMMAND EXECUTION

- 1000 Last text string before end of current step of operation
- 1001 Text records to follow.
- 1002 Spectral data records to follow.

The following sections list commands, their associated parameters and output.

Unless otherwise stated all commands that have associated parameters will return the current value of the parameter(s) if the command is sent with no parameters and there is no error. The format of the response is: 0000c/r l/f <parameter values>c/r l/f 0000c/r l/f

Parameter values will be an ASCII representation of the value of the same type as the parameter specified for input. Multiple parameters are separated by commas. Asterisks are used to denote parameter values outside permitted ranges.

Monochromator Scan Control Commands

Command: ABSCISSA HIGH LIMIT

Syntax: \$AH <abscissa limit>

Description: Sets either a new emission or excitation high abscissa limit depending on monochromator selection. Emission limit must be in range 200.0 to 900.0. Excitation limit must be in range 200.0 to 800.0. Limits are rounded to nearest 0.1 and are in units of wn. A high limit must be greater than the corresponding low limit. Power-on defaults for high limits are: 800 for excitation and 900 for emission. Returns high limit for selected monochromator if no parameter is specified.

NOTE: Excitation limit is set if monochromator selection is 'both'. Refer to command \$MX.

Command: ABSCISSA LOW LIMIT

Syntax: \$AL <abscissa limit>

Description: As for high limit. Power-on defaults for low limits are 200 for both. Returns low limit for selected monochromator if parameter is not specified.

Command: MONOCHROMATOR SELECTION QUALIFICATION

Syntax: \$MQ qualifier

Description: Causes subsequent scans of both monochromators to be 'constant wavelength' if qualifier = 0, or 'constant frequency' if qualifier =1. Qualifier must be integer. Power-on default is 0.

Command: MONOCHROMATOR SELECTION

Syntax: \$MX code

Description: Sets specified monochromator selection for subsequent scans: Code = 0 Excitation only, 1 Emission only, 2 Both. Returns error 0111 if emission or both selected with emission mirror in. Power-on default is 0.

Command: SCAN

Syntax: \$SC start type

Description: Starts a scan according to start type (1 = immediate; 2=after START event detected). If the first error code indicated no error then a scan status record is sent. The monochromators are driven to the start positions specified by \$AL, \$AH, \$SS and \$MX commands.

Data records are then sent as data become available. An error code is sent on completion of the scan. A data record consists of 10 successive output points. A last record is padded with representations of the value -9999 and contains at least one of these. A data record is transmitted either in ASCII or binary. In ASCII mode points are separated with commas. In binary mode a 4 byte representation is sent with the least significant bytes foremost. Each real output value is an integer in the range -5000 to +999999 ('+' sign suppressed) and is derived from the data available in the data processing chain multiplied by the scale factor and truncated to integer. A data point appended with an exclamation mark (!) indicates that an event was detected during its collection.

A scan status record consists of the following:

```
55.<rev>,<ms><mq><dc><fi>,<ex.wavelength>,<em.slit width>,<max.points>,<data.int>.
```

Fields within the record separated by commas are of fixed length and are left-filled with spaces. Parameters in angle brackets are substituted as follows (x = ASCH digit, space, or minus):

<rev> is 2 character integer representing software revision. The first character corresponds to the software release number.

<ms> is a single character integer code representing current monochromator selection (see \$MX command).

<mq> is a single character integer code representing current monochromator selection qualifier (see \$MQ command).

<dc> is a single character integer code representing current data collection mode (see \$PH command).

<fl> is a single character integer code representing current filter type (see \$FL command).

<ex.wavelength> is fixed format (xxx.x) representing the excitation monochromator position at the start of the scan in nm.

<em.wavelength> is fixed format (xxx.x) representing the emission monochromator position at the start of the scan in nm.

<speed> is a 4 digit integer representing speed in nm/min. A leading minus is given for negative speeds.

<response> is a 3 digit integer representing current filter response number.

<ex. slit width> is fixed format (xx.x) representing the excitation slit width in nm.

<em. slit width> is fixed format (xx.x) representing the emission slit width in nm.

<max.points> is a 5 digit integer representing the maximum number of real data points that may be returned in the scan.

<data.int> is fixed format (xxxx.x) representing the abscissa interval between points in nm.

Command: SCAN DATA INTERVAL

Syntax: \$SI interval

Description: Sets data output interval for subsequent scans. Interval is in range 0.1 to 5 nm and is rounded to nearest multiple of 0.1 nm. Current interval is returned if no parameter specified. Power-on default is 0.5 nm.

Command: SCAN SPEED
Syntax: \$SS speed
Description: Sets the speed for subsequent scans. Speed may be integer in range 10 to 1500 or -1500 to -10 and has units of nm/min. Power-on default is 480. Returns scan speed if no parameter specified.

Time Drive Commands

Command: TIME DRIVE
Syntax: \$TD points
Description: Causes a time drive returning the specified number of points. Points is an integer in the range 1 to 99999. An error code is returned immediately. If no error is indicated a time drive status record is sent followed by data records as the data become available. Data records are as per SCAN command. An error code is returned on completion. Returns error 0005 if no parameter specified.

A time drive status record consists of the following:

```
55.<rev>,<ms><mq><dc><fi>,<ex.wavelength>,  
<em.wavelength>,<speed>.<response>,  
<ex.slitwidth>,<em.slitwidth>,<max.points>,<data.int> c/r l/f  
0000 c/r l/f
```

Fields within the record separated by commas are of fixed length and are left-filled with spaces. Parameters in angle brackets are substituted as follows (x = ASCH digit, space, or minus):

<rev> is two character code representing software revision.

<ms> is a single character integer code representing current monochromator selection (see \$MX command).

<mq> is a single character integer code representing current monochromator selection qualifier (see \$MO command).

<dc> is a single character integer code representing current data collection mode (see \$PH command).

<fl> is a single character integer code representing current filter type (see \$FL command).

<ex.wavelength> is fixed format (xxx.x) representing the excitation monochromator position in nm.

<em.wavelength> is fixed format (xxx.x) representing the emission monochromator position in nm.

<speed> is a 4 digit integer representing current scan speed in nm/min. A leading minus is given for negative speeds.

<response> is a 3 digit integer representing current response time (units 0.01s) (Refer to \$RT).

<ex.slitwidth> is fixed format (xx.x) representing the excitation slit width in nm.

<em.slitwidth> is fixed format (xx.x) representing the emission slit width in nm.

<max.points> is a 5 digit integer representing the maximum number of real data points that may be returned in the time drive.

<data.int> is fixed format (xx.xx) representing the abscissa interval between points in seconds.

Command:	RESPONSE TIME
Syntax	\$RT time
Description	<p>Set the time drive response time to the specified value (0 to 9.99 s, rounded down to nearest 0.02 s). Positive values turn filter and block average priming off; hence a propagation delay equal to the response time will occur before the first data point is ready for output. Negative values cause the filters to be fully primed with the first point; hence the propagation delay is zero but noise artifacts may distort initial data points output up to the response time.</p> <p>A value of zero sets minimum response time consistent with the time interval and allows manual control of filter width. Power-on default is 0.</p> <p>Returns current response time if no parameter is specified.</p>

Command: TIME INTERVAL

Syntax: \$TI time

Description: Sets the time drive time interval. Time must be in range 0.02 to 99.98 and is rounded to 0.02. Units are seconds. Power-on default is 0.5 s.

Command: PHOSPHORESCENCE DECAY TIME DRIVE

Syntax: \$DP points

Description: Turns the source off and immediately starts a time drive with specified number of points output. Syntax and output format exactly as for \$TD command. One data collection cycle will elapse between the source going off and the start of data collection. Raw data are smoothed according to current \$RT setting.

Command: REMOTE TRIGGERED TIMEDRIVE

Syntax: \$DS points

Description: Starts TimeDrive when START signal is detected. Specified number of points output. Syntax and output format exactly as for \$TD command. Raw data are block averaged according to current \$RT setting. \$AB aborts command before or after remote signal is detected.

Command: REMOTE TRIGGERED PHOSPHORESCENCE DECAY TIMEDRIVE

Syntax: \$PR POINTS

Description: Starts phosphorescence decay TimeDrive when START signal is detected. Specified number of points output. Syntax and output format exactly as for \$DP command. Raw data are block averaged according to current \$RT setting. \$AB aborts command before or after remote signal is detected.

TLC Scan Commands

Command: TLC DATA INTERVAL
Syntax: \$IT interval
Description: Sets data output interval for subsequent TLC scans. Interval is in range 0.1 to 2 mm and is rounded to nearest multiple of 0.1 mm. Power-on default is 0.5 mm.

Command: TLC X AXIS-HIGH LIMIT
Syntax: \$XH limit
Description: Sets high limit for TLC x scan. Range 0.1 to 99.0 mm. High limit may not be lower than TLC x low limit. Power-on default is 63.0 mm.

Command: TLC X AXIS LOW LIMIT
Syntax: \$XL limit
Description: Sets low limit for TLC x scan. Range 0 to 98.9 mm. Low limit may not be higher than TLC x high limit. Power-on default is 0 mm.

Command: TLC Y AXIS HIGH
Syntax: \$YH limit
Description: Set high limit for TLC y scan. Range 0.1 to 63.0 mm. High limit may not be lower than TLC y low limit. Power-on default is 63.0 mm.

Command: TLC Y AMS LOW
Syntax: \$YL limit
Description: Set low limit for TLC y scan. Range 0 to 62.9 mm. Low limit may not be higher than TLC y high limit. Power-on default is 0 mm.

Command: TLC SCAN SPEED

Syntax: \$TS speed

Description: Sets speed for subsequent TLC scans. Speed is integer in range -600 to 600 mm/min. Power-on default is 300 mm/min.

Command: TLC X SCAN

Syntax: \$TX

Description: Starts TLC x scan. An error code is returned immediately. If no error is indicated a TLC scan status record is sent followed by data records as the data becomes available. Data records are as per Scan command. An error code is returned on completion.

A TLC scan status record consists of the following:

```
50.<rev>,<ms><mq><dc><fl>,<ex.wavelength>,  
<em.wavelength>,<speed>,<response>,<ex.slitwidth>,  
<em.slitwidth>,<max.points>,<data.int> c/f l/f 0000 c/r l/f
```

Fields within the record separated by commas are of fixed length and are left-filled with spaces. Parameters in angle brackets are substituted as follows (x = ASCII digit, space, or minus):

<rev> is two character code representing software revision.

<ms> is a single character integer code representing current monochromator selection (see \$MX command).

<mq> is a single character integer code representing current monochromator selection qualifier (see \$MQ command).

<dc> is a single character integer code representing current data collection mode (see \$PH command).

<fl> is a single character integer code representing current filter type (see \$FL command).

<ex.wavelength> is fixed format (xxx.x) representing the excitation monochromator position in nm.

<em.wavelength> is fixed format (xxx.x) representing the emission monochromator position in nm.

<speed> is a 4 digit integer representing speed in mm/min. A leading minus is given for negative speeds.

<response> is a 3 digit integer representing smoothing filter response width (000 to 101).

<ex.slitwidth> is fixed format (xx.x) representing the excitation slit width in nm.

<em.slitwidth> is fixed format (xx.x) representing the emission slit width in nm.

<max.points> is a 5 digit integer representing the maximum number of real data points that may be returned in the scan.

<data.int> is fixed format (xxxx.x) representing the abscissa interval between points in mm.

Command: TLC Y SCAN

Syntax: \$TY

Description: Starts TLC y scan. See TLC X SCAN command for further information.

Command: MOVE TO TLC X POSITION

Syntax: \$XM position

Description: Moves plate reader x-axis motor to the position specified. The position may be in the range 0 to 99.0 mm and is rounded to the nearest multiple of 0.1 mm. Power-on default is 0.

Command: MOVE TO TLC Y POSITION

Syntax: \$YM position

Description: Moves plate reader y-axis motor to the position specified. Position may be in the range 0 to 63.0 mm and is rounded to the nearest multiple of 0.1 mm. Power-on default is 0.

Data Collection/Processing Set Up Commands

Command: EXCITATION CORRECTION SELECTION

Syntax: \$CX code

Description: Selects the excitation correction to be applied. Code is integer with following values: 0 no correction, 1 correction. Power-on default is 1.

NOTE: Scan and time drive commands return error code 0111 if no valid correction data in non-volatile memory and the code is 1.

Command: PHOSPHORESCENCE DARK CURRENT SELECT

Syntax: \$DC code

Description: Selects whether a dark current of zero or one generated by the SET DARK CURRENT command is used. Code is 0 for dark current = 0, 1 otherwise. Power-on default is 0.

Dark current value is subtracted from the emission main signal on-the-fly before block averaging and ratioing (see \$OS command).

Returns current dark current value if no parameter is specified.

Command: FILTER SELECT

Syntax: \$FL code

Description: Selects the filtering applied in the data processing. Code is integer with one of following values: 0 Savitsky-Golay filter, 1 Binomial filter. Power-on default is 0.

Command: FILTER RESPONSE

Syntax: \$FR response number

Description: Sets the active data processing filter characteristics for subsequent data processing. Response number must be an odd integer in range 3 to 101. Power-on default is response 19. Returns response of currently active filter if no parameter is specified.

Command: PHOSPHORESCENCE CYCLE

Syntax: \$PC time

Description: Sets phosphorescence mode cycle time. Time is an integer in the range 0 to 9999 and has units of ms. If a time of zero is specified then the cycle time will be set to the minimum value required given current data collection parameters.

Returns error 0103 if time specified cannot be accommodated with current phosphorescence data collection parameters. Power-on default is to set minimum cycle time.

Command: PHOSPHORESCENCE DELAY

Syntax: \$PD time

Description: Sets specified phosphorescence delay time for any subsequent phosphorescence mode data collection. Time is an integer in range 0 to 900 000 and has units of 0.01 ms. Error 0103 is returned if the time requested is greater than can be accommodated with current phosphorescence data collection parameters. Power-on default is 100 (1 ms).

Command: PHOSPHORESCENCE FLASH COUNT

Syntax: \$PF count

Description: Sets the number of flashes per phosphorescence data collection cycle. Count is integer in range 1 to 10. Returns error 0103 if flash count requested cannot be accommodated with current phosphorescence data collection parameters. Power-on default is 1.

Command: PHOSPHORESCENCE GATE

Syntax: \$PG time

Description: Sets specified phosphorescence gate time. Time is an integer in the range 1 ms to 50 000 ms. It can be incremented in steps of 0.01 ms. Returns error 0103 if requested time cannot be accommodated with current phosphorescence data collection parameters. Power-on default is 100 (1 ms).

Command: PHOSPHORESCENCE/ FLUORESCENCE MODE

Syntax: \$PH mode

Description: Mode is an integer with values: 0 sets normal fluorescence mode, 1 sets phosphorescence mode, 2 sets bioluminescence mode. Power-on default is 0. The current selection is returned if no parameter is specified.

Command: READ SINGLE DATA VALUE

Syntax: \$RD time

Description: Performs a read operation averaging data for the time specified. Time is in range 0.1 to 100.0 seconds. If successful a no error response is sent immediately, then a single point data record followed by a final error code. Single point data record format:

<ex.wavelength>,<em.wavelength>,<temp>,<intensity>

wavelength format xxx.x, temp format xxx.x (°C) if biokinetic accessory is fitted (else ***), intensity format xxxxxx(!) (!=EVENT detected during data collection).

Final error 0107 is returned if a PMT error was detected during this operation \$RD 0 gives immediate output of an average of the last four intensity values collected during the idle time drive.

NOTE: The temperature is not updated during idle TimeDrive. The current integration time is returned if no parameter is specified.

Command: SET PHOSPHORESCENCE DARK CURRENT

Syntax: \$SD data collection cycles.

Description: The specified number of data collection cycles are averaged to produce the dark current reading. Data collection cycles must be an integer in the range 1 to 1000. The default when the power is switched on is 10 cycles the dark current is set to zero. Returns error code 0103 if not in phosphorescence or bioluminescence mode.

Command: SET AUTOZERO

Syntax: \$AZ, data collection cycles.

Description: Uses current data collection parameters to average the specified number of data collection cycles to produce a zero offset reading to be subtracted from all subsequent data before output. Data collection cycles must be integer and in the range 1 to 1000. Returns current autozero offset if no parameter given. \$AZ 0 sets offset zero (autozero off). Power-on default is autozero off.

Command: SET AUTOCONC

Syntax: \$AC concentration value

Description: Uses current data collection parameters to average 100 data collection cycles to produce a standard intensity reading. This reading is output in single point format (refer to \$RD) and is ratioed with the specified concentration value to give a scaling factor (concentration/intensity) which is applied to all subsequent data output. Concentration value must be integer in the range 100 to 999999. Returns current scaling factor (format xxxxx.xxxx) if no parameter given. \$AC 0 set autoconc off. Power-on default is autoconc off.

Data Output Control Commands

Command: OUTPUT SELECT

Syntax: \$OS selection

Description: Selects the data in the data processing chain to be output on subsequent scans or time drives. Returns current selection if no parameter is specified.

Selection is an integer of one of the following values, power-on default is filtered data:

0	Excitation main integration data
1	Excitation dark integration data
2	Emission main integration data
3	Emission dark integration data
4	Excitation dark subtracted data
5	Emission dark subtracted data
6	Excitation corrected data
7	Emission corrected data
8	Excitation block averaged data
9	Emission block averaged data
10	Ratioed data
11	Normalized data
12	Filtered data

NOTE: Selections 0 - 10 cannot be guaranteed to produce the quantity or abscissa interval of output points given in the scan/time drive status line during a data collection operation.

Command: ANALOGUE OUTPUT OFFSET
Syntax: \$O1 OFFSET
Description: Sets the analogue output offset. Added to output voltage after scaling. Offset is an integer in the range 0 to 10000 and has units of mV (0 - 10 V output) and 0.1 MV (0-1 V output). Power-on default is 0.

Command: ANALOGUE OUTPUT SCALE
Syntax: \$SI factor
Description: Sets the analogue output scaling factor. Factor is integer and may be in range 1 to 10 000. Units are microvolts at the 0 - 10 V output per intensity unit as output from the RS232C channel. Power-on default scaling factor is 10.

Command: SPECTRAL DATA TRANSMISSION MODE
Syntax: \$DT mode
Description: Sets data transmission mode for scan and time drive data output: 0 = ASCII, 1 = binary. Power-on default is 0.

Motor Control

Command: EXCITATION SHUTTER
Syntax: \$ES position
Description: Causes the source to be turned off. (Treated conceptually as a mechanical shutter). Position is an integer and may adopt the values: 0 = out (source on), 1 = in (source off). Returns position if no parameter is specified. Power-on default is 0.

Command: FILTER WHEEL

Syntax: \$FW position

Description: Causes the emission filter to change to the specified position. Position is an integer and may adopt the values:

- | | |
|---|-----------------------------|
| 1 | 290 nm cutoff filter |
| 2 | 350 nm cutoff filter |
| 3 | 390 nm cutoff filter |
| 4 | 430 nm cutoff filter |
| 5 | 530 nm cutoff filter |
| 6 | blank |
| 7 | no filter (clear) |
| 8 | 1% transmittance attenuator |

Power-on default is 7. Returns filter number if no parameter is specified.

Command: GOTO MONOCHROMATORS

Syntax: \$GM excitation abscissa value, emission abscissa value

Description: Drives both monochromators simultaneously to the specified wavelengths. Abscissa values must be zero or in the range 200.0 to 800.0 (excitation) and 200.0 to 900.0 (emission,) and are rounded to the nearest 0.1. Units are nm, zero corresponds to zero order position. Returns current wavelengths if no parameters specified. If either parameter is null, the corresponding monochromator does not move. Power-on defaults are 365.0 and 435.0 nm.

NOTE: No data are output during a GOTO.
--

Command: EMISSION MIRROR

Syntax: \$MM position

Description: Moves emission mirror (if fitted) either in (position=1), or out (position=0). Error 0111 is returned if emission or both monochromators are selected. Power-on default is 0.

Command: EMISSION POLARIZER
Syntax: \$PM position
Description: Sets the position of the emission polarizer wheel if fitted. Position is an integer and may have the following values:
0 clear, 1 vertical polarization filter, 2 horizontal polarization filter.
Power-on default is 0.

Command: EXCITATION POLARIZER
Syntax: \$PX position
Description: Sets the position of the excitation polarizer wheel if fitted. Position is an integer and may have the following values:
0 clear (automatic cutoff filter select), 1 vertical polarizer, 2 horizontal polarizer, 3 blank, 9 clear (fixed, no automatic cutoff filter). Power-on default is 0. Returns current position if no parameter specified.

NOTE: Cutoff filter position 5 returned if selected.

Command: EMISSION SLIT
Syntax: \$SM position
Description: Sets the position of the emission slit. Position is in range 0 to 20 nm and is rounded to the nearest multiple of 0.1 nm.
Power-on default is 1 nm.

NOTE: Slit positions below 2.5 nm are uncalibrated.

Command: EXCITATION SLIT
Syntax: \$SX position
Description: Sets the position of the excitation slit. Position must be in the range 2.5 to 15 nm and is rounded to the nearest multiple of 0.1 nm. Power-on default is 10 nm.

NOTE: Slit positions below 2.5 nm are uncalibrated.

Calibration Commands

Command: CORRECTION TABLE GENERATION

Syntax: \$CR

Description: Starts automatic generation of excitation correction table.

Command: CALIBRATE CONTINUE

Syntax: \$CT

Description: Request to continue calibration operation. Used in response to request for action during calibration.

Command: EMISSION MONOCHROMATOR CALIBRATION

Syntax: \$MC

Description: Starts automatic emission monochromator calibration.

Command: EMISSION SLIT CALIBRATION

Syntax: \$MS

Description: Starts automatic calibration of the emission slit.

Command: EXCITATION MONOCHROMATOR CALIBRATION

Syntax: \$XC

Description: Starts automatic calibration of the excitation monochromator.

Command: EXCITATION SLIT CALIBRATION

Syntax: \$XS

Description: Starts automatic calibration of the excitation slit.

Miscellaneous Commands

- Command: ABORT
- Syntax: \$AB
- Description: Aborts scan, time drive, GOTO, wait for external input, pump drive, FKA/FFA run or calibration operations. Returns error 0110 if the active command not abortable or error 0002 if no command is active.
- Command: ACCESSORIES FITTED
- Syntax: \$AF
- Description: Returns code indicating which accessories are attached as fitted and ready for use. Code format is a comma separated list of ASCII digits with: 0 = not fitted, 1 = fitted.
- Order of codes: Emission mirror, plate reader, excitation polarizer, emission polarizer, cell holder, well plate reader, stirrer, temperature controller, peristaltic pump, autosampler, FFA excitation unit, FFA emission unit.
- Command: NON-VOLATILE MEMORY ERROR STATUS
- Syntax: \$ME
- Description: Returns error code 0000, 0108, or 0106 depending on state of non-volatile memory.
- Command: PMT ERROR
- Syntax: \$PT
- Description: Returns an error code of 0107 if a PMT error was detected since the last occurrence of this command or power-on.

Command: SET PMT VOLTAGE

Syntax: \$PV voltage

Description: Sets specified PMT voltage to override default setting determined by excitation slit width. Valid voltage range 0-999 V. Parameter -1 sets default voltages defined according to the excitation slit position. Power-on default is -1. Returns actual value of voltage if no parameter given. An A after the voltage value indicates automatic mode.

Command: RESPOND

Syntax: \$RE mode

Description: Sets free running output if mode = 0, or prompted output if mode = 1. Mode is an integer. Power-on default is 1.

Command: STATUS

Syntax: \$ST

Description: An initial error response is sent. If this response indicates no error then the following status record is sent followed by another no error response.

A status record consists of the following:

55,<rev>,<ms><mq><dc><fi>,<ex.wavelength>,
<em.wavelength>,<speed>,<response>,<ex.slitwidth>,
<em.slitwidth>,<gate>,<delay>,<flashcount>,<cyc.time>

Fields within the record separated by commas are of fixed length and are left-filled with spaces. Parameters in angle brackets are substituted as follows (x = ASCII digit, space, or minus):

<rev> is two character code representing software revision.

<ms> is a single character integer code representing current monochromator selection (see \$MX command).

<mq> is a single character integer code representing current monochromator selection qualifier (see \$MQ command).

<dc> is a single character integer code representing current data collection mode (see \$PH command).

<fl> is a single character integer code representing current filter type (see \$FL command).

<ex.wavelength> is fixed format (xxx.x) representing the excitation monochromator position in nm.

<em.wavelength> is fixed format (xxx.x) representing the emission monochromator position in nm.

<speed> is a 4 digit integer representing speed in nm/min. A leading minus is given for negative speeds.

<response> is a 3 digit integer representing current filter response number.

<ex.slitwidth> is fixed format (xx.x) representing the excitation slit width in nm.

<em.slitwidth> is fixed format (xx.x) representing the emission slit width in nm.

<gate> is a 5 digit integer representing current phosphorescence gate time, units 0.01 ms.

<delay> is 6 digit integer representing current phosphorescence delay time, units 0.01 ms.

<flashcount> is a 2 digit integer representing current number of flashes per phosphorescence data collection cycle.

<cyc.time> is a 5 digit integer representing current data collection cycle length in ms (may be zero in fluorescence mode to indicate default 1 mains period).

Command: WAIT FOR EXTERNAL SIGNAL

Syntax: \$WE signal

Description: Waits for a transition on one of the external digital inputs:
0 = positive transition on EVENT line, 1 = positive transition on START line.

NOTE: On earlier issue instruments the EVENT line is labeled REMOTE START and the START line is labeled REMOTE INTEGRATE.

Command: WARM START

Syntax: \$WS

Description: Causes warm start and transfers valid calibration data to motor stepping software. Returns error 0106 or 0108 if there is a non-volatile memory error.

Command: MAINS FREQUENCY

Syntax: \$HZ

Description: Returns the frequency of the mains supply to the instrument.

Command: SERIAL NUMBER

Syntax: \$SN

Description: Returns the serial number of the instrument.

Plug-in Accessory Control Commands

Command: RETURN TEMPERATURE

Syntax: \$TP

Description: Returns temperature XX.X °C as measured at sensor. Returns error 0100 if temperature sensor accessory not fitted.

Command: TEMPERATURE OFFSET

Syntax: \$TO offset

Description: Returns temperature offset if no offset parameter sent, or sets the offset if an integer between 0 and 50 is used.

Command: INITIALIZE CELL HOLDER

Syntax: \$CI

Description: Drives cell holder to datum position. Used after any manual change to cell holder accessory.

Command: MOVE CELL HOLDER

Syntax: \$CM position

Description: Moves cell holder to the specified position. Position is an integer in the range 1 to 4. Initialization default is 1.

Command: PERISTALTIC PUMP BLOW

Syntax: \$PB time

Description: Causes the peristaltic pump to blow for the specified time. Time is in the range 0.1 to 100 s and is rounded to 0.1 s

Command: PERISTALTIC PUMP SUCK

Syntax: \$PS time

Description: Causes peristaltic pump to suck for the specified time. Time is in the range 0.1 to 100 seconds and is rounded to nearest multiple of 0.1 s. Power-on default is 0.

Command: SET STIRRER SPEED
Syntax: \$SF speed code
Description: Set stirrer speed according to single digit speed code: 0 = off, 1 = low, 2 = high. Power-on default is 0.

Well Plate Reader (WPR) Commands

Command: FIND DATUM
Syntax: \$FD
Description: Locates the datum point of the well plate reader or returns an error.

Command: MOVE PLATE READER
Syntax: \$MP x-coordinate y-coordinate
Description: Moves plate reader to position corresponding to the coordinates given, where x can be 0 to 128 and y can be 0 to 86.

Command: PARK
Syntax: \$PP
Description: Moves the plate reader to the parked position and returns 0000 when finished.

Command: MOVE TO WELL NUMBER
Syntax: \$WP well no.
Description: Moves plate reader to position corresponding to well no. Well no. is an integer in the range 1 to 96.

Fast Kinetics Application (FKA) Commands

Command: FKA WAVELENGTHS 1
Syntax: \$W1 ex wavelength, em wavelength
Description: Sets wavelengths for first output data point of FKA run (and subsequent alternate data points). If no parameters are given, outputs current setting (power-on default 340 and 510 nm). If only one parameter given, assumes other wavelength to be current monochromator position.

Command: FKA CYCLE TIME
Syntax: \$FC time
Description: Sets FKA cycle time (interval between successive points output) for FKA runs. Time format xxx.x (seconds). Zero time sets minimum possible cycle time for current \$RD integration time, data collection cycle length, and wavelengths \$W1 and \$W2. Power-on default 2.1 s. Minimum value for \$RD 0.1 and default W1, W2 is 1.6 s. Returns error 0009 if requested time is smaller than current minimum possible time. Returns current cycle time if no parameter is given.

Command: FKA WAVELENGTHS 2
Syntax: \$W2 ex wavelength, em wavelength
Description: Sets wavelength for second output data point of FKA run (and subsequent alternate data points). If no parameters are given, outputs current setting (power-on default 380 and 510 nm). If only one parameter given, assumes other wavelength to be current monochromator position.

Command: FKA RUN
Syntax: \$FK points
Description: Starts FKA run to produce specified number of data points. Syntax is as for \$TD command. Output format is: 0000.

<spectral data records as for time drive giving intensities for wavelengths W1,W2,W1 ... > <terminating record containing at least one -9999 value> <final error code as for time drive>

NOTE: No status line is output.

Command: REMOTE TRIGGERED FKA RUN
Syntax: \$FF points
Description: Starts FKA run when START signal detected. Syntax and output format are as for \$FK.

Command: RESPOND

Syntax: \$RE mode

Description: Sets free running output if mode = 0, or prompted output if mode = 1. Mode is integer. Power-on default is 1.

\$RE 1 clears any DC1 prompts stored in the instrument. Free running mode should be selected when a terminal is used to communicate with the instrument. Prompted mode must be selected before control is returned to the PC.

NOTE: A DC1 prompt for the error code from the \$RE 1 command must be sent from the terminal before, control is finally returned to the PC. Control-E sent to the instrument toggles character echo from the instrument. Echo must be turned off before control is returned to the PC.

Command: ENTER/EXIT SOFTWARE MONITOR MODE

Syntax: \$BE

Description: \$BE 6161 causes entry into software monitor mode. A diagnostic software monitor task known as the multi-tasking executive monitor (MTEM) is started. The first action of MTEM is to output a record of the first few hundred commands sent to the instrument since last power on or last \$BE 6161 command (whichever is more recent). The listing can be stopped by sending DC3 (cntrl-S) and continued with DC1 (cntrl-Q). MTEM can then be used to control and record the operation of the instrument's real-time executive. \$BE (no parameter) causes exit from the software monitor mode. \$BE must be sent before control is returned to the PC.

Fast Filter Accessory (FFA) Commands

Command: SET EXCITATION UNIT STATE

Syntax: \$FX state

Description: Sets excitation unit state if fitted. Valid states are: 0 clear beam (power-on default), 1 position 1, 2 position 2, 3 position 3, 4 position 4, 8 running synchronous. If no parameter is specified, the current excitation unit state is returned.

Command: SET EMISSION UNIT STATE

Syntax: \$FM state

Description: Sets emission unit state if fitted. Valid states are as for \$FX command. If no parameter is specified, the current excitation unit state is returned. Error code 0100 means units are not fitted. Error code 0112 signifies a synchronization error.

NOTE: Excitation and emission units may not be run simultaneously.

Command: SET FFA CYCLE LENGTH

Syntax: \$FI time

Description: Sets FFA data output cycle length rounded up to next multiple of 4 mains cycles from input time; time range 0.00 - 9.99s.

Command: COLLECT FFA DATA

Syntax: \$XF cycles, prompt

Description: Starts FFA data collection and output. Data points are output in format as for \$FK command, but in cycles of four, with the first point always corresponding to the first filter position flashed after the datum position for the currently rotating unit.

The specified whole number of cycles worth of data points are output (range 1 - 99999). The cycle duration is as specified by the \$FI setting. Cycle lengths > 4 mains cycle, data is block averaged. No smoothing or normalization is applied to the data regardless of the \$0\$ state.

The optional prompt parameter specifies one of EVENT(0) or START(1) input line triggers for-data collection and output.

Returns error code 0005 if no parameters given, error code 0111 if no FFA unit running, error code 0112 if synchronization error occurs, error code 0099 if aborted

System Description and
Maintenance

The Optical System

The excitation source is a special xenon flash tube, which produces an intense, short duration pulse of radiation over the spectral range of the instrument. A small festoon lamp close to the excitation source maintains an even triggering of the xenon flash tube. The path of the radiation is shown in Figure 112. Energy from the source is focused by the ellipsoidal mirror M(E)5 and reflected by the toroidal mirror onto the entrance slit of the Excitation monochromator. The monochromator consists of the entrance slit, a grating, a spherical mirror and an exit slit. A narrow wavelength band emerges from the exit slit, with the center wavelength being determined by the setting of the grating, the angle of which is controlled by a stepper motor. The majority of the excitation beam is transmitted to the sample area via the focusing toroidal mirror M(T)1, a small proportion is reflected by the beamsplitter onto the reference photodiode. To correct for the response of the reference photodiode a rhodamine correction curve is stored within the instrument. Rhodamine dye absorbs energy from 230 to 630 nm and fluoresces at about 650 nm with nearly constant quantum efficiency.

Energy emitted by the sample is focused by the toroidal mirror M(T)1₁ onto the entrance slit of the Emission monochromator. The monochromator consists of the entrance slit, a spherical mirror M(S)3₁, a grating and the exit slit. A narrow wavelength band emerges from the exit slit, with the center wavelength being determined by the setting of the grating, the angle of which is controlled by a stepper motor. The Excitation and Emission monochromators can be scanned over their ranges independently, synchronously or driven to selected points in their ranges.

Synchronous scanning can be either a fixed wavelength difference or a fixed energy difference between the excitation and emission monochromators. The spectral ranges of the monochromators are:

- Excitation monochromator 200 nm to 800 nm and zero order
- Emission monochromator 200 nm to 900 nm and zero order

NOTE: UV output from a xenon source falls off rapidly at wavelengths below 230 nm. New sources have more energy in this region.

The spectral response of the standard photomultiplier with modified SS response falls to zero at wavelengths greater than 650 nm. For applications in the region up to 900 nm use a red sensitive photomultiplier.

The slit widths may be varied to give resolutions between 2.5 nm to 15 nm for the Excitation monochromator and between 2.5 nm to 20 nm for the Emission monochromator in increments of 0.1 nm. The value of 0 can also be selected for both the excitation and emission slit and this gives a resolution of < 2 nm.

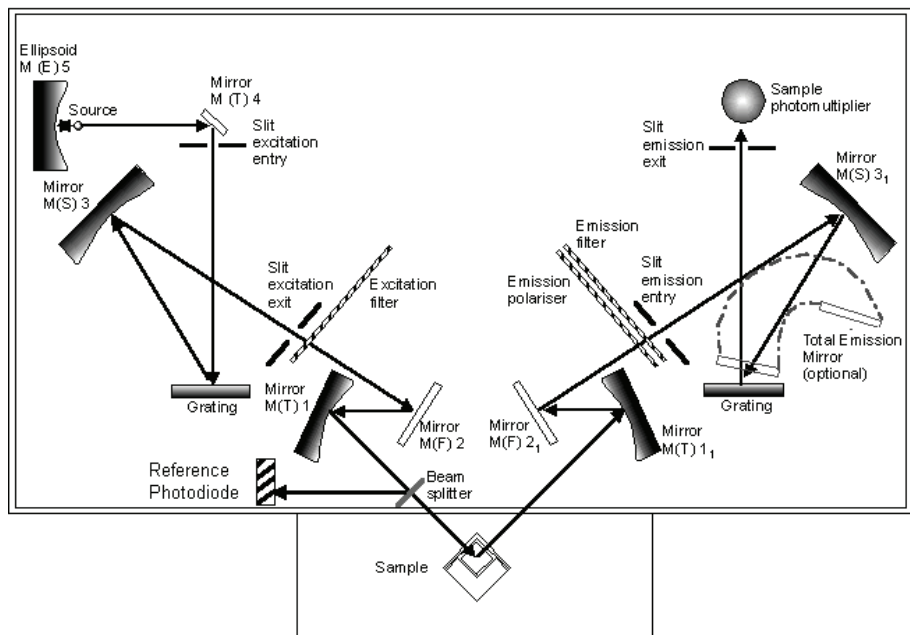

Figure 112 The optical layout

The Electronics System and Signal Handling

For each data collection cycle spectral data are obtained from the photomultipliers. The data signals undergo integration, conversion, averaging, digital filtering and ratioing before the PC receives the data. The path of the data signals through the LS 55 is shown in the electronics diagram and in the signal-handling diagram. The electronics diagram is shown in Figure 113.

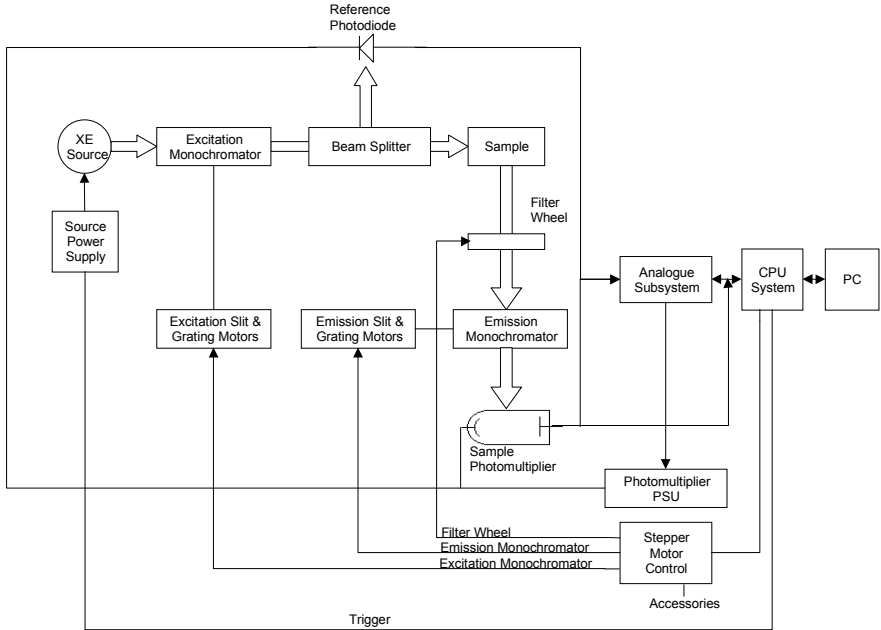

Figure 113 Electronics diagram

Instrument Modes

Fluorescence

When the instrument is operating in the fluorescence mode four integrations are performed for every data collection cycle. Two integrations are taken from the emission channel and two from the excitation channel. These integrations are performed at fixed times with respect to the last source flash.

An integration is taken of both the excitation and emission main signals. Emission from the source has a width at half peak height of less than 10 microseconds, the integrators are opened for 80 microseconds to collect all the signal. The effect of dark current (signal produced when no light is falling on the photomultiplier) is eliminated by gating open both channels a second time just before the next flash and integrating the signal. The dark current signals are then subtracted from the main fluorescence signals to give a dark current corrected signal.

Phosphorescence

When the instrument is operating in the phosphorescence mode the emission integration time is not fixed, but can be selected by the user. The integration can be started between 0 seconds and 9000 milliseconds after the start of the flash. This is the **delay** time. The time period over which the integration is performed, the **gate** time, can be varied from 0.01 milliseconds to 500 milliseconds. If the sum of the delay and gate times exceeds 13.0 milliseconds the cycle time must be increased to allow a longer data collection period.

The source can be pulsed between 1 and 10 times, to optimize the sample excitation and data collection. The exciting pulses occur on consecutive mains cycles at the start of the data collection cycle. The gate and delay times are measured from the beginning of the last pulse in the excitation pulse train. On initiating a phosphorescence measurement the dark current is measured and the value stored and subtracted from all sample signals.

Chemi- and Bio-luminescence

When the instrument is operating in the chemi- or bio-luminescence mode the source is switched off. Data signals are therefore only received from the sample photomultiplier. The integration time ranges are the same as for phosphorescence, but the signal is not ratioed. On initiating a bioluminescence measurement the dark current is measured and the value stored and subtracted from all sample signals.

Signal Conversion

After integration the photomultiplier signals are multiplexed, fed into the auto-ranging amplifier and then into the 12-bit successive approximation Analogue to Digital (A-D) converter. The auto-ranging amplifier increases the gain of the signal to optimize the A-D conversion. The conversion is obtained by using a 12 bit DAC (digital to analogue) converter and a comparator, where a 12 bit word is successively approximated to the analogue signal, with the control loop being supervised by the on-board microprocessor. The dark current is digitally subtracted from the reference signal and likewise from the sample signal, to give a true zero.

The DAC is also used to drive the analogue outputs such as chart recorders and other accessories.

Block Averaging

During scanning, the signal from the data collection cycle is block averaged, the degree of averaging being dependent upon the scan speed selected and the data interval. If the number of collection cycles is a non-integer, then the block average width is set to the smaller integer value. With the default data interval of 0.5 nm, examples of the number of collection cycles that are averaged for various scan speeds is shown in the table below.

Scan Speed nm/min	Block Average Width (50 Hz)	Block Average Width (60 Hz)
30	50	60
120	12	15
480	3	3
1500	1	1

Time Drive

In the time drive mode the amount of block averaging is determined by the value of the response time specified. The amount of block averaging is adjusted (taking into consideration the operating frequency of the instrument) to produce a 2% to 98% response to step signals over the specified response time. The default response time is 0.5 seconds.

Ratioing and Correction

After the sample and reference channels have been block averaged, they are ratioed to improve the signal to noise and to remove source related artifacts. This ratioed output is then scaled to either the wavelength range scanned or the time scale chosen to give the corrected result. The results are multiplied by the rhodamine correction curve, which is stored in the instrument, to correct for the spectral response of the photomultiplier tubes and the transmission response of the beamsplitter.

Signal Handling Diagram

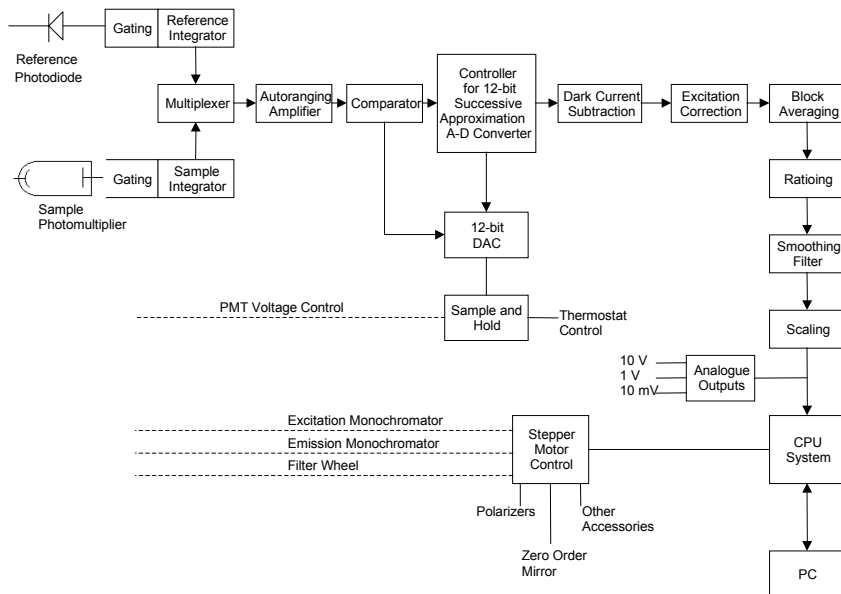

Figure 114 The signal handling diagram

Fuses

These are **OPERATOR** replaceable fuses.

These are NOT IEC fuses, but are CSA approved fuses.

CAUTION

For instruments set to 100 to 120 Volts supply voltage:

Fuse	Location	Current rating	Voltage rating	Type	PerkinElmer part number
Mains Input	Mains input panel	2A	250V	CSA:Time lag	0C97 3134

For instruments set to 220 to 240 Volts supply voltage:

Fuse	Location	Current rating	Voltage rating	Type	PerkinElmer part number
Mains Input	Mains input panel	1A	250V	CSA:Time lag	0C96 2348

For details on how to change the fuse, see *Changing the mains fuse* on page 196.

Other Fuses

These other fuses must not be replaced by an **OPERATOR**, they may only be replaced by a **RESPONSIBLE BODY** who is aware of the hazards involved.

Fuse	Location	Current rating	Voltage rating	PerkinElmer part number
	Source board	100mA, T	250V	04969185
FS1	Motor Control board	500mA, T	250V	04967940
FS2	Motor Control board	2A, T	250V	04970839



Using the instrument in a manner not specified herein may impair the protection provided by the instrument.

Removing the Main Cover



Removing this cover will give access to hazardous voltages.



WARNING

*Any adjustment, maintenance, or repair of the opened, operating instrument, must be performed by a skilled person who is aware of the hazards involved (a **RESPONSIBLE BODY**).*

The main cover is hinged along the rear edge of the instrument.

1. Switch off the instrument and disconnect the electrical mains supply.
2. Position the LS 55 on the front of the bench so that it overhangs the bench by approximately 8 cm.
3. Loosen the two screws located on the left-hand and right-hand underside of the instrument, as shown in Figure 115.

They are captive so will remain in the instrument.



Figure 115 Cover locking screws

4. Open the sample compartment cover.

5. Lift the main cover and rest it on the stay located on the right-hand side, as shown in Figure 116.

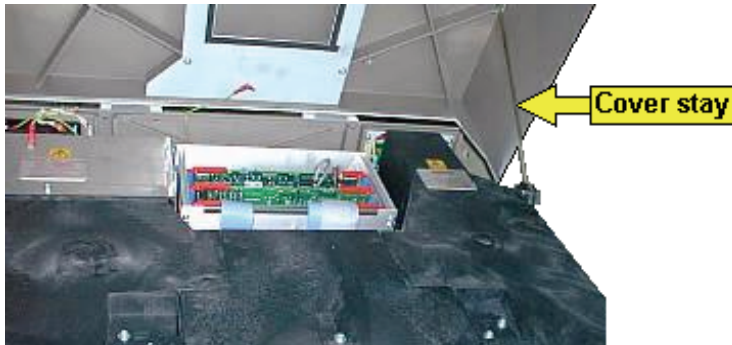

Figure 116 Cover stay

6. Unclip the earth lead from the cover, as shown in Figure 117.

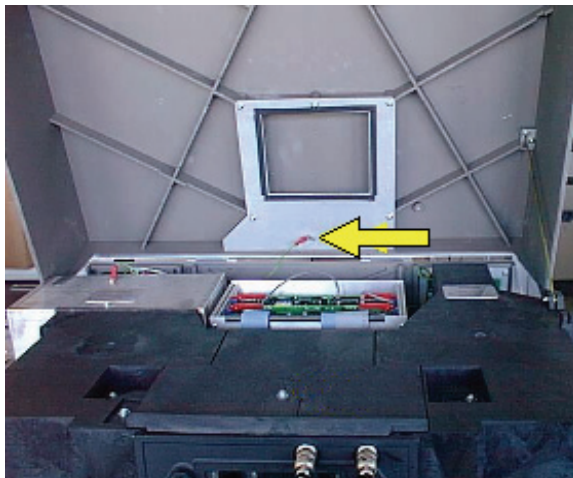

Figure 117 Unclipping the earth lead

7. Open the cover to an angle greater than 90 degrees to the bench. From this position the cover can be lifted off its hinges.

Refitting the main cover

To replace the cover proceed as follows:

1. Place the cover on its hinges.
2. Close the cover slightly and attach the earth lead.
3. Close the cover and tighten the screws to secure the cover.

Removing the Main Optical Cover

1. Remove the main cover as described in *Removing the Main Cover* on page 173.
2. Undo the 3 screws which secure the middle optical cover, as shown in Figure 118 and Figure 119.

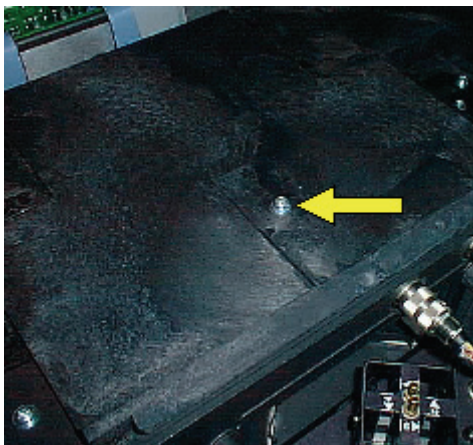

Figure 118 Center screw

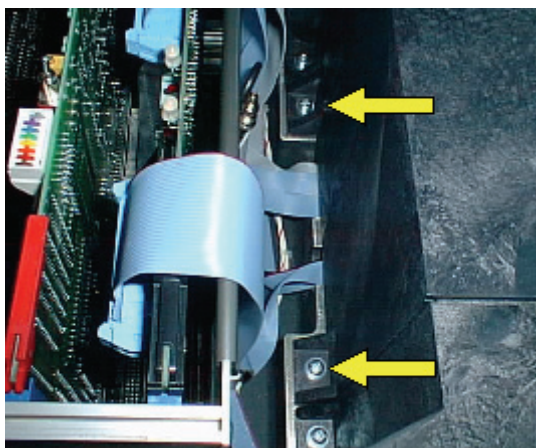

Figure 119 Rear screws

3. Remove the middle optical cover by lifting it vertically, as shown in Figure 120.



Figure 120 Lifting the cover

CAUTION

Be careful not to touch any of the optical surfaces (mirrors or windows).

Refitting the optical cover

1. Replace the middle optical cover, locating the central groove as shown Figure 121.

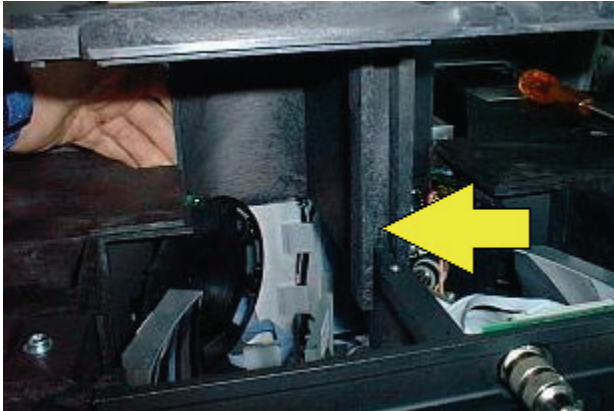

Figure 121 Replacing the main optical cover

2. Secure the three screws.
3. Replace the main cover, including the earth lead.

Customizing filter wheels



WARNING

*Any adjustment, maintenance, or repair of the opened, operating instrument, must be performed by a skilled person who is aware of the hazards involved (a **RESPONSIBLE BODY**).*



Switch off the mains supply switch of the LS 55 and remove the mains supply cable - the xenon lamp uses high voltages, which could lead to a lethal electric shock if the above precaution is not taken.

The LS 55 is fitted as standard with an excitation filter wheel and an emission cut-off filter wheel. On installation of the polarizers, an additional emission filter wheel is fitted. The excitation filter wheel and emission polarizer have free positions that have no fitted filters: the user can fit interference or high pass filters into these open positions if desired. Furthermore, the filters in the standard emission cut-off filter wheel can be changed if desired.

In all of these cases, FL WinLab must be informed of the changes. This is done by entering information into the file LS55.INI that is located in the **flwinlab** directory. Information about the updated filters is entered into the section headed 'ACCESSORY', the three lists under this header refer to the respective filter wheels as follows:

- ExFilter = Excitation filter wheel (standard)
- EmFilter = Emission filter wheel (standard)
- EmPole = Emission polarizer filter wheel (optional)

For the excitation filter wheel and emission polarizer wheel, free positions are labelled as 'custom filter n'. For the standard emission filter wheel the filter from an existing position must be replaced (note that position 7 must be left open for the clear beam position).

Changes should be made to the LS55.INI file, which must then be saved.

To confirm which positions are referred to in the file, the filter wheels can be observed by the following steps:

1. Open the top cover of the LS 55 as described in *Removing the Main Cover* on page 173.
2. Switch off the photomultiplier voltage switch.
3. Remove the central optical cover.
4. Using the LS 55 Status application, send the filter wheel to a desired position.
5. Observe the filter wheel inside the central optical area.

NOTE: Many of the above steps are described graphically in the accessories section of this handbook.

The listing of the relevant section of LS55.INI follows. Open filter wheel positions are shown in bold and italic script:

```
[ACCESSORY]
PMT_Type=std
ExFilter 1=clear (auto cutoff on)
ExFilter 2=vertical polariser
ExFilter 3=horizontal polariser
ExFilter 4=blank
ExFilter 5=custom filter 1
ExFilter 6=auto ex cut off filter
ExFilter 7=custom filter 2
ExFilter 8=UG 5
ExFilter 9=clear (auto cutoff off)
EmFilter 1=290nm Cut-off
EmFilter 2=350nm Cut-off
EmFilter 3=390nm Cut-off
EmFilter 4=430nm Cut-off
EmFilter 5=515nm Cut-off
EmFilter 6=closed
EmFilter 7=open
EmFilter 8=1%T attenuator
EmPole 1=clear
EmPole 2=vertical polariser
EmPole 3=horizontal polariser
EmPole 4=blank
EmPole 5=custom filter 1
EmPole 6=custom filter 2
EmPole 7=custom filter 3
EmPole 8=custom filter 4
```

Changing the Lamp



WARNING

*Any adjustment, maintenance, or repair of the opened, operating instrument, must be performed by a skilled person who is aware of the hazards involved (a **RESPONSIBLE BODY**).*



Switch off the mains supply switch of the LS 55 and remove the mains supply cable - the xenon lamp uses high voltages, which could lead to a lethal electric shock if the above precaution is not taken.

1. Open the top cover of the LS 55 as described in *Removing the Main Cover* on page 173.
2. Locate the metal lamp housing (located rear-left), and remove the earth contact, as shown in Figure 122.
3. Undo the cover fixing screw, as shown in Figure 122.

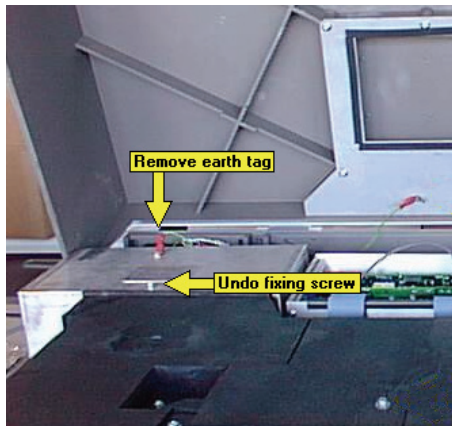

Figure 122 Earth connection and cover screw

4. Lift the metal cover vertically away from the LS 55, as shown in Figure 123, and store it securely.



Figure 123 Lifting the cover

5. Locate the lamp and the two electrode connectors, as shown in Figure 124.

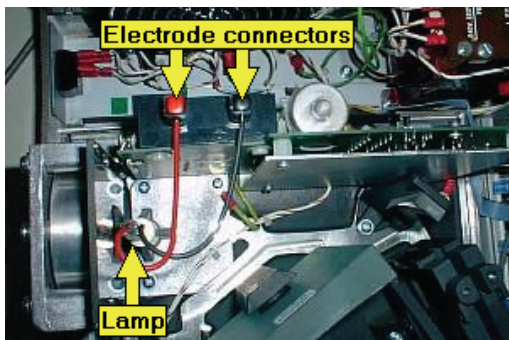

Figure 124 Locating the parts

6. Press each connector in turn and remove the cables, as shown in Figure 125.

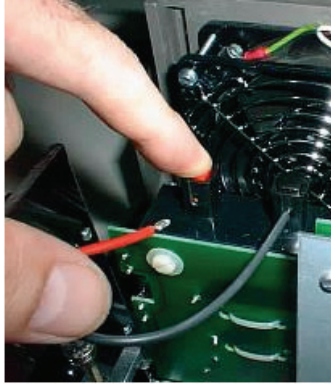

Figure 125 Disconnecting the cables

7. Loosen the grub screw at the bottom of the lamp holder bracket, as shown in Figure 126.

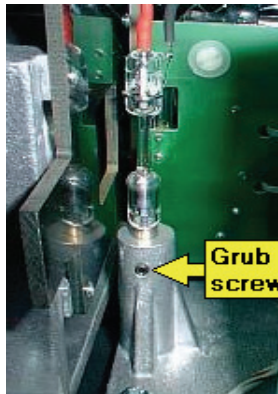

Figure 126 Loosen the grub screw

8. When the screw is correctly loosened, the lamp can be easily pulled vertically out of its bracket.

NOTE: If force is required, then the screw is still not loose enough.

CAUTION

Excessive force will break the lamp, leaving sharp pieces in the lamp housing.

9. Remove the new lamp from its packaging.

CAUTION

Take care-the lamp is EXTREMELY sensitive. A slight knock against the table surface, for example, can immediately break the lamp. Also take care not to touch the lamp, or the central capillary section could become contaminated leading to serious loss of sensitivity. If the capillary is accidentally touched, wipe immediately with spectroscopic grade ethanol or methanol and dry with a cuvette-wipe tissue.

NOTE: In order to seat the lamp correctly in the bracket, it needs to be rotated before insertion into the bracket so that it is correctly aligned with the optical system.

10. Turn the lamp so that the trigger strip, as shown in Figure 127, is located to the right, pointing towards the small mirror next to the entrance slit, as shown in Figure 128.

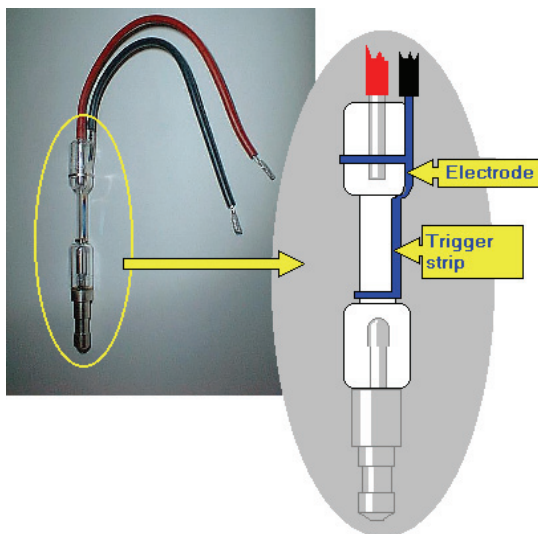

Figure 127 Details of the electrode

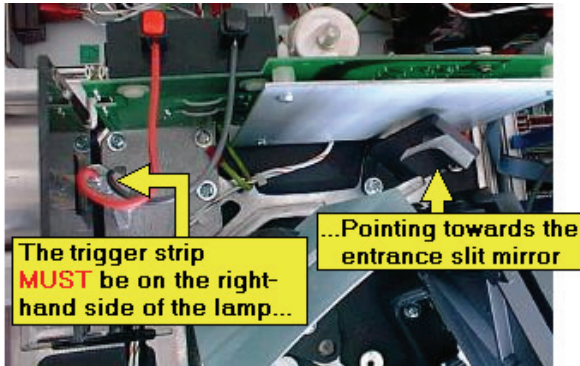

Figure 128 Aligning the electrode

11. Insert the new lamp into the lamp holder bracket.
There should be little resistance, but if this is not the case, loosen off the grub screw.

CAUTION

Use of excessive force when inserting the new lamp will most probably break it.

12. When the lamp has been fully inserted into the bracket, gently tighten the grub screw.

NOTE: The grub screw does not need to be overtight. Once the grub screw makes contact with the lamp post, this is tight enough. Overtightening could lead to scoring on the column of the lamp, making future removal difficult.

13. Connect both electrode cables by depressing the connector, inserting the cable, and releasing the connector, as shown in Figure 129.

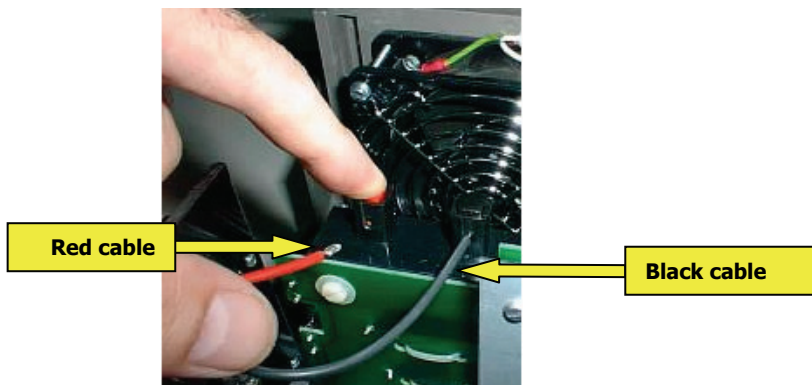

Figure 129 Connecting the cables

14. Locate the metal cover into the slot around the optical cover, and gently lower the metal cover taking care that no cables are trapped underneath, as shown in Figure 130.

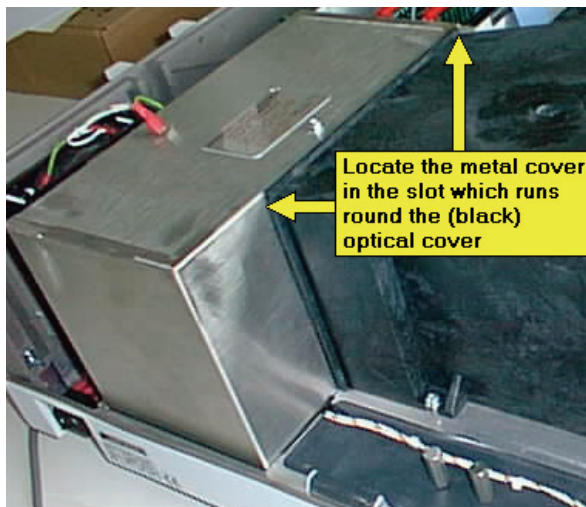

Figure 130 Replacing the cover

15. Re-connect the earth tag and replace the fixing screw, as shown in Figure 131.

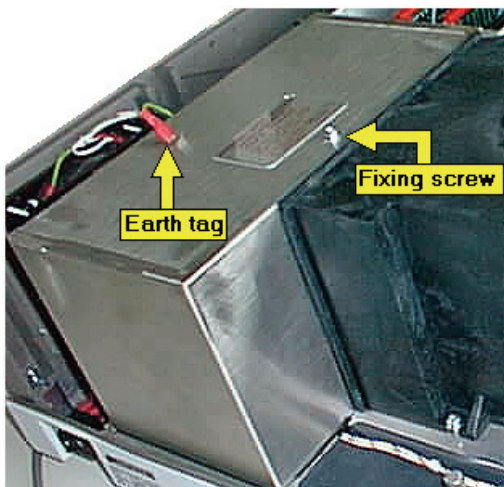

Figure 131 Earth lead and fixing screw

16. Close the main instrument cover.
17. Plug in the mains supply cable and switch on the LS 55.

The performance of the LS 55 with the new lamp fitted can be tested using the FL WinLab validation routine. A silica cuvette with deionized water is inserted into the cuvette holder, and then the routine is started by selecting **Validate LS 55** on the Applications menu in FL WinLab.

The routine will prompt you for the water-filled cuvette, then will measure and display the signal-to-noise value for the instrument, and the wavelength accuracy.

Preparing the LS 55 for transport

The LS 55 is extremely robust, and needs only to have its shipping clamps secured before transporting.

Always insert the shipping clamps before moving the LS 55.

CAUTION

Never forget to remove the shipping clamps before switching on the LS 55 again - or the calibration of one or both monochromators could be severely corrupted leading to gross wavelength errors.

Inserting the clamps

1. Switch on the LS 55 and allow it to initialize fully.
If the LS 55 is already running, then switch it off and on again.
This is because the instrument is automatically driven to lock-down monochromator positions at the end of initialisation.



WARNING

Switch off the mains supply switch of the LS 55 and remove the mains supply cable before continuing this procedure.

2. Switch off the LS 55 and remove the mains supply cable.
3. Open the main cover as detailed in *Removing the Main Cover* on page 173.
4. Remove the two shipping clamp plates, by undoing the screws that hold them in place, as shown in Figure 132.



Figure 132 Removing the shipping clamp plates

5. Remove the two shipping clamp screws from their storage positions on the left-hand side of the LS 55, as shown in Figure 133.

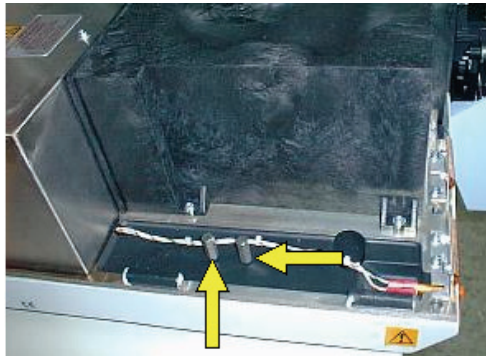

Figure 133 Shipping clamp screws storage positions

6. Screw the shipping clamp screws into the screw threads revealed when the plates were removed, as shown in Figure 134.



Figure 134 Inserting the shipping clamp screws

7. Replace the shipping clamp plates, by turning them through 180° to align the hole with the shipping clamp screw, as shown in Figure 135.

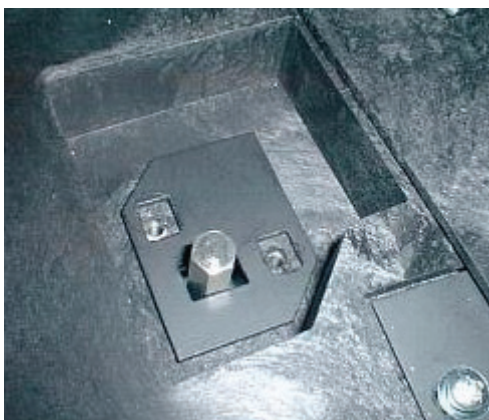

Figure 135 Replacing the shipping clamp plates

8. Secure the plates with the two screws, as shown in Figure 136.

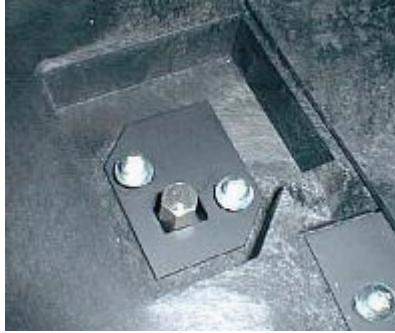

Figure 136 Screwing down the plates

9. Close the main cover.

Lifting the LS 55 Luminescence Spectrometer



Consult local codes of practice issued by safety advisors before attempting to lift the spectrometer.

As the LS 55 Luminescence Spectrometer weighs approximately 49 kg (approximately 59 kg with packaging), we recommend that the spectrometer is lifted by 2 adults, and that it is lifted by the base of the instrument.

Removing the clamps

Once the LS 55 has been moved to its new position, remove the clamps as detailed in *Removal of the shipping clamps* on page 26.

Cleaning the LS 55

Always switch off the power and remove the power cord before cleaning.

CAUTION

You can clean the outside of the LS 55 using a damp cloth. Mild detergent may be used, if necessary. Always perform a patch test on an inconspicuous area of the instrument before you clean the entire instrument.

Avoid spilling liquid into the instrument. Clean all external spills immediately. If anything that is spilled enters the main body of the LS 55, switch off the power and call a PerkinElmer Service Engineer.

Cleaning the air filter

In normal operating conditions the air filter should be cleaned every time the source is replaced. The air filter is situated on the right-hand side of the rear panel, as shown in Figure 137.

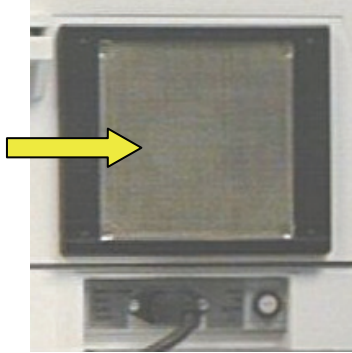

Figure 137 The air filter

The air filter is cleaned as follows:



WARNING

Switch off the mains supply switch of the LS 55 and remove the mains supply cable before starting this procedure.

1. Switch off the LS 55 and remove the mains supply plug.
2. Place a flat bladed screwdriver in one of the two slots on the right side of the air filter holder and then lever off the air filter holder.
3. Remove the air filter.
4. Clean off dust from the filter grid.
5. Replace the grid in the holder and refit the filter holder by snapping in to place.
6. Reconnect the mains cable and switch on.

Changing the Instrument Operating Voltage



WARNING

*Any adjustment, maintenance, or repair of the opened, operating instrument, must be performed by a skilled person who is aware of the hazards involved (a **RESPONSIBLE BODY**).*



WARNING

Switch off the mains supply switch of the LS 55 and remove the mains supply cable before starting this procedure.

The operating voltage of the instrument can be changed by altering the connections on the mains transformer, located inside the instrument.

1. Switch off the instrument and disconnect the electrical mains supply.
2. Open the main cover as detailed in *Removing the Main Cover* on page 173.

CAUTION

Do not change any of the terminal connections on the right-hand side of the transformer (viewed from the front of the instrument).

The mains transformer is located at the rear of the instrument. On the left-hand side of the transformer (viewed from the front) are five terminals with the voltages they each correspond to marked on the top of the transformer, as shown in Figure 138.

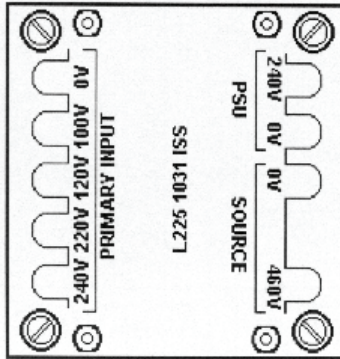

Figure 138 Connections to the transformer

The wire connections to the terminals are as follows:

Wire	Colour	Terminal
Line	Brown	100V, 120V, 220V or 240V
Fan	Blue	0V
Fan	Red	120V or 100V
Neon Lamp	Orange	220V or 240V
Neon Lamp	Black	0V

Change the connections on the transformer as follows:

3. Disconnect the terminal (brown) wire from the current terminal.
This will be connected to either the 240V, 220V, 120V or 100V terminal.
4. Connect the brown wire to the terminal marked with the required operating voltage.

NOTE: The 240V connection should be used for 230V supplies.

5. Ensure that the operating voltage plate shows the correct operating voltage.
The appropriate operating voltage may be displayed on the reverse of the current plate, or on the spare plate shipped with the instrument (L2251188 Mains Label 100 V / 220 V).

NOTE: The fan can be operated from either the 100V or 120V terminal. If an operating voltage of 100V is selected the red fan wire should be connected to the 120V terminal and vice versa.

NOTE: The neon lamp can be operated from either the 220V or 240V terminal. If an operating voltage of 220V is selected the orange lamp wire should be connected to the 240V terminals and vice versa.

Changing the mains fuse

Having changed the operating voltage of the instrument the mains fuse must be changed to correspond with the operating voltage. The table below gives the correct fuse rating for the operating voltage.

Operating Voltage	Mains Fuse Rating	PerkinElmer Part Number
220-240 V 50/60 Hz	1A Slo Blo	OC97 3107
100-120 V 50/60 Hz	2A Slo Blo	OC97 3134

The mains fuse is located on the mains input panel at the rear of the instrument, as shown in Figure 139.



Figure 139 The position of the mains fuse

1. Undo the screw in the end of the fuse holder.
2. Pull the fuse out.
3. Fit the replacement fuse.
4. Refit the screw.

The mains voltage plate

NOTE: The mains voltage plate (on the mains input panel) must always indicate the voltage to which the instrument is set.

The correct mains voltage may be written on the current double-sided plate or on the spare plate shipped with the instrument (L2251188 Mains Label 100 V / 220 V). The voltage plate is secured by two screws, which also secure the mains socket.

To change the voltage plate, proceed as follows:

1. Remove the two screws from the mains socket.
2. Carefully pull out the mains socket a small distance so that the voltage plate is released.
3. Place the correct plate behind the mains socket with the appropriate side facing outwards.
4. Push the mains socket back into place and replace the two screws.

The LS 55 can now be connected to the alternate mains voltage.



Index

Index

A

About This Manual.....	14
accessories	
cellchanger.....	40
cellholders.....	38, 39, 41
external fibre optic.....	87
fast filter	94
flowcell	43
front surface	66
LC flowcell.....	63
plate reader	73
polarizer.....	105
red sensitive detector.....	83
sipper	57
spares.....	120
total emission.....	85
accessory connectors.....	29
air filter.....	193
analogue output commands	128
autosampler connection	32

B

biokinetic accessory	
commands	129
biokinetics accessory	41

C

care of optical mirrors.....	55
cellholders	
cleaning	56
cellholders	
biokinetics accessory.....	41
care of optical mirrors	55
minimizing volume.....	51
resistance to solvents.....	56
screw fitting flowcell	43
semi-micro cuvette	52
septum injector	48
single position	38

stirred four position cellchanger	40
stirred semi-micro cuvette	53
stirred single position	39
stirrer bars.....	50
thermostatting tubing.....	45
changing the lamp	181
changing the mains fuse	196
changing the operating voltage ..	194
cleaning	
cellholders	56
cleaning the air filter	193
cleaning the LS 55	192
connecting to a PC.....	31
connections.....	29
accessory connectors	29
autosamplers	32
chart recorders	31
connection to a PC.....	31
event marks	31
mains supply	29
remote starts.....	31
RS232C connection	31
scan busy	32
terminal block.....	31
conventions.....	14
definitions.....	17
Conventions	
text.....	14
customizing the filter wheels	179

D

description	
electronics system.....	166
fuses.....	171
optical system.....	164
signal handling.....	166

E

electrical connections.....	29
electronics system	166
environmental conditions	8

event mark connection31
 external fibre optic accessory87

F

fast filter accessory94
 commands 129
 filter motor commands 128
 filter wheel 179
 filters 179
 four position cellchanger
 commands 129
 front surface accessory66
 fuse
 changing..... 196
 fuses 171

I

inserting the shipping clamps..... 188
 introduction 22

L

lamp 181
 LC flowcell63
 lifting25

M

main cover 173
 mains fuse..... 196
 mains supply 29
 mains voltage plate 197
 maintenance
 care of optical mirrors.....55
 changing the lamp..... 181
 changing the mains fuse..... 196
 changing the operating voltage194
 cleaning the air filter..... 193
 cleaning the LS 55..... 192
 customizing the filter wheels ... 179
 main cover 173
 main optical cover 176
 preparing for transport 188
 moving 188

O

opening the main cover173
 operating voltage194
 operator..... 17
 optical system164

P

peristaltic pump
 commands129
 photomultiplier
 red sensitive..... 83
 photomultiplier control commands
 128
 plate reader
 commands129
 driver commands127
 plate reader accessory 73
 polarizer accessory105
 power switch..... 34
 preparing for transport188

R

red sensitive detector 83
 refitting the main cover.....175
 refitting the main optical cover178
 remote start connection 31
 removing the main cover173
 removing the main optical cover ..176
 removing the shipping clamps 26
 replacing the main cover175
 responsible body 17
 RS232 commands.....122
 analogue output128
 command formats.....131
 fast filter accessory129
 filter motor128
 photomultiplier control128
 plate reader driver127
 sample aquisition129
 slit motor128
 source control.....128
 RS232C communications125
 RS232C connections 31

S

safety information	8
scan busy connection	32
screw-fitting flowcell	43
semi-micro cuvette	52
septum injector	48
shipping clamps	26
inserting	188
shipping kit	24
signal handling	166
single position cellholder	38
sipper accessory	57
slit motor commands	128
software	
anisotropy	110
filter setup	102
polarization	110
sipper control	60
well plate reader	80
source control commands	128
spares for accessories	120
specifications	18
standard cellholder	38

start up	34
starting	34
stirred four position cellchanger	40
stirred semi-micro cuvette	53
stirred single position cellholder	39
stirrer bars	50
stirring samples	50
switching on	34

T

temperature control	45
terminal block	31
thermostating tubing	45
total emission accessory	85

V

voltage	194
---------------	-----

W

warning labels	10
well plate reader software	80